

EL-PRESS

ELECTRONIC PRESSURE METERS AND CONTROLLERS



PRESSURE RANGES:

MIN. 0-100 MBAR; MAX. 0-400 BAR

HIGH ACCURACY AND REPEATABILITY

COMPACT ARRANGEMENT

FOR LIQUIDS AND GASES

THRU-FLOW DESIGN

BRONKHORST
HI-TEC

INTRODUCTION AND CONTENTS

INTRODUCTION

This brochure describes the instruments of the EL-PRESS series. These Electronic Pressure Meters and Controllers for gases and liquids are of modular construction. Absolute, relative and differential pressure sensors are available. All metal sealed Pressure Meters/Controllers of the COMBI-FLOW series are described in a separate brochure. Furthermore your local distributor will gladly advise you on ex-proof pressure measurement and control systems. For Bronkhorst Hi-Tec's product line of Mass Flow Meters/Controllers please refer to page 15 or our general brochure.

CONTENTS

	PAGE
About Bronkhorst High-Tech	3
EL-PRESS Electronic Pressure Meters	4
EL-PRESS Electronic Pressure Controllers	5
EL-PRESS @digital Pressure Meters/Controllers	6
Technical specifications	7
Control Valves	8 - 9
Model number identification	10
Applications	11
Readout Systems, digital	12 - 13
Readout Systems, analog	14
Other BRONKHORST HI-TEC products	15

ABOUT BRONKHORST HIGH-TECH

PRODUCT RANGE

Bronkhorst High-Tech B.V. was established in 1981 and now offers a very wide range of thermal and coriolis mass flow meters and controllers. Numerous styles of both standard and customized instruments can be offered for applications in laboratory, industrial and hazardous areas. The full scale measuring range (with 50:1 turn-down) for these instruments can be selected between 0...1 ml_n/min and 0...10000 m_{3n}/h for gases and 0...30 mg/h up to 0...600 kg/h for liquids.

Furthermore Bronkhorst High-Tech offers pressure transducers and controllers with a minimum range of 0...100 mbar and a maximum range of 0...400 bar.



ROUND-THE-CLOCK SUPPORT

Bronkhorst High-Tech is a truly worldwide organisation with its Head Office being located in the town of Ruurlo in The Netherlands. With a total head-count now exceeding 230 employees, it is impressive that 45 of these are involved with R&D, 100 in manufacture and 40 involved with after-sales service and customer care. In actual fact, the Customer Service Department offers "round-the-clock" support, seven days a week, to customers in every corner of the world.



SALES REPRESENTATION AND SERVICE

In addition to the sales office in Veenendaal of The Netherlands there are branch offices in Great Britain, France, Switzerland and northern Germany whereby local expertise and service is offered. Bronkhorst High-Tech has also built up an extensive complimentary network of distributors and service stations across the rest of Europe and, indeed, yet further representation in such countries as the USA, Japan, Australia, New Zealand, Canada, Israel, India, South Africa, Brazil and Korea.



QUALITY

Customer satisfaction, innovation and quality of product and service have been the cornerstones of Bronkhorst High-Tech's success. In 1987 the company obtained the Koning Willem I Award for a young successful enterprise and in 1992 the company was accredited to ISO 9001 with ISO

14001 (an International Standard for environmental management) following three years later. In January 2004 this ongoing commitment was rewarded by accreditation to the most recent Quality Management System, ISO 9001:2000.



EL-PRESS ELECTRONIC PRESSURE METERS

GENERAL

The EL-PRESS series P-500 Electronic Pressure Meters have a well-proven compact thru-flow design, and are available in pressure ranges from 100 mbar up to 400 bar, both in absolute pressure and relative pressure. In the range of 100 mbar up to 15 bar a differential pressure transmitter can also be supplied. The instruments are of modular construction with an electronic housing suitable for common laboratory type ambient conditions. In order to convert an electronic pressure transmitter to a controller, a control valve is used; normally the control valve would be integrated (see next page), but it can also be mounted separately.

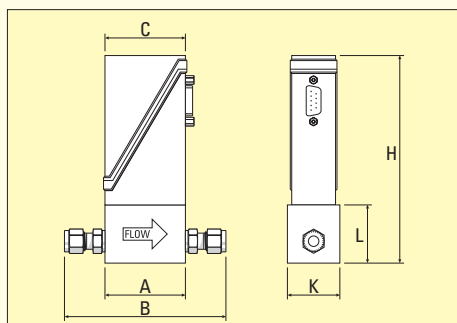

PRESSURE METER

Model	Dimensions (mm)						Weight (kg)
	A	B	C	H	K	L	
P-502C/P-512C/P-522C/P-532C	47	97	47	123	30	37	0,4

DIFFERENTIAL PRESSURE METER

Model	Dimensions (mm)						Weight (kg)
	A	B	C	H	K	L	
P-506C	55	105	47	116	30	30	0,4



EL-PRESS P-506C EPT

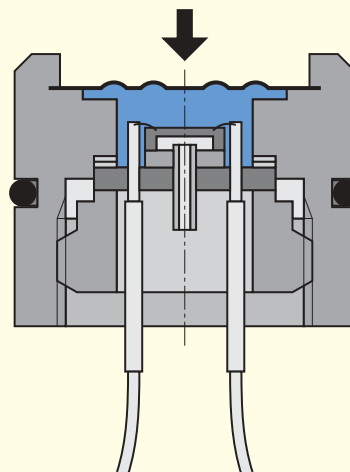

CROSS SECTIONAL DRAWING OF A PRESSURE SENSOR

PRINCIPLE OF OPERATION

The Bronkhorst Hi-Tec EL-PRESS pressure sensor is a piezo resistive bridge on the surface of a silicon chip. This chip is drilled out on its reverse side, giving the inside of the chip the form of a pressure diaphragm whose thickness determines the pressure range. When a pressure acts on this chip, the diaphragm flexes, and the resistor values of the bridge alter in proportion to the pressure. The measuring cell is separated from the external pressure by a thin, sensitive stainless steel diaphragm, and the sealed off cavity between diaphragm and cell is filled with oil.

PRESSURE RANGES (INTERMEDIATE RANGES ARE AVAILABLE)

Pressure Meters (absolute or relative)

Model P-502C	min. 2100 mbar	max. 1,2864 bar
Model P-512C	min. 1,2864 bar	max. 2100 bar
Model P-522C	min. 2100 bar	max. 4200 bar
Model P-532C	min. 4200 bar	max. 8400 bar

Differential Pressure Meters

Model P-506C	min. 2100 mbar	max. 0,315 bar
--------------	----------------------	----------------------

EL-PRESS ELECTRONIC PRESSURE CONTROLLERS

GENERAL

The EL-PRESS Electronic Pressure Controllers are compact devices, comprising an integrated pressure transducer and control valve for K_v -values up to $6,6 \times 10^{-2}$. For higher flows we recommend to use a separate P-500 pressure transducer, preferably to be mounted outside the flow stream to eliminate frictional losses, and a special, patented Bronkhorst Hi-Tec control valve for K_v -values up to 6,0. To cope with high differential pressure a VARY-P control valve can be offered; the maximum possible differential pressure across this device is 400 bar.

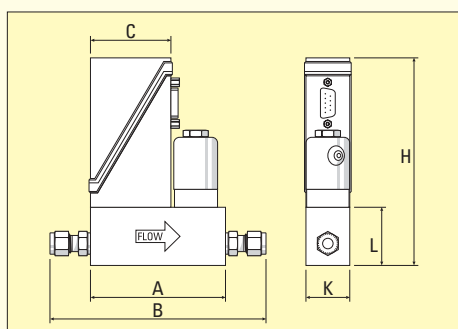

FORWARD PRESSURE CONTROLLER

Model	Dimensions (mm)						Weight (kg)
	A	B	C	H	K	L	
P-602C/P-612C	77	127	47	123	25	37	0,7

BACK PRESSURE CONTROLLER

Model	Dimensions (mm)						Weight (kg)
	A	B	C	H	K	L	
P-702C/P-712C	77	127	47	123	25	37	0,7



EL-PRESS P-702C EPC

For pressure control applications with small pressure differences, series F-004 bellows operated valves can be offered. See pages 8 and 9 for a description of the various control valves.

FIELDS OF APPLICATION

Chromatography

Programmable pressure profile in

- gas chromatography
- liquid chromatography

Biotechnology

- Fermenter pressure control

Semiconductor Industry

- Vapour pressure control MOCVD
- Chamber pressure control in CVD and sputtering equipment

Surface treatment technology

- Source pressure control ($TiCl_4$)
- Protective gas pressure control in aluminium extrusion moulding processes

Research laboratories

- Pressure control in combustion studies
- Liquid level control in reactor vessels

PRESSURE RANGES (INTERMEDIATE RANGES ARE AVAILABLE)

Forward Pressure Controllers (absolute or relative)

Model P-602C	min. 5100 mbar	max. 3,264 bar
Model P-612C	min. 3,264 bar	max. 5100 bar*

Back Pressure Controllers (absolute or relative)

Model P-702C	min. 20100 mbar	max. 12,864 bar
Model P-712C	min. 12,864 bar	max. 20100 bar*

* For pressures up to 400 bar select P-532C Pressure Meter with F-033C Control Valve

EL-PRESS® DIGITAL PRESSURE METER/CONTROLLER

GENERAL

Pressure meters and controllers of the EL-PRESS series are also available in a digital version. As is often the case, pressure meters in their standard analog construction are then furnished with AD/DA converters and so made digital. Not so in our case.

EL-PRESS digital is based on a new digital PC-board on which the sensor signal is sent direct to a micro processor. By doing so an optimum signal stability and accuracy is achieved. An integral alarm function continuously checks the difference between the set-point- and the measured value. If, for example, the supply pressure of a pressure controller drops and therefore the downstream pressure can no longer be controlled, the instrument gives a warning. In addition the instrument checks itself through an integral, self diagnosis routine.

MULTI-BUS TECHNOLOGY

Bronkhorst High-Tech B.V. developed their latest digital instruments according to the 'multi-bus' principle. The basic PC-board on the instrument contains all of the general functions needed for measurement and control. It has analog I/O-signals and also an RS-232 connection as a standard feature. In addition to this

there is the possibility of integrating an interface board with DeviceNet™, Profibus-DP®, Modbus or FLOW-BUS protocol. The latter is a fieldbus based RS485, specifically designed by Bronkhorst High-Tech B.V. for their mass flow and pressure metering and control solutions, and through which the company already has fifteen years of experience with digital communication.

To support PC/PLC controlled process control Bronkhorst High-Tech has devised various software programmes, for instance a DDE-server for parameter exchange with MS WINDOWS application programmes. Furthermore Bronkhorst High-Tech offers free software tools for fieldbus connection and for monitoring, optimizing and operation of digital instruments.

SPECIFICATIONS

Digital Pressure Meter/Controller

- Digital input/output (DeviceNet™, Profibus-DP®, Modbus or FLOW-BUS operation) or analog (0...5 (10) V, 0 (4)...20 mA).
- Interchangeable with analog instruments.
- Accuracy: $\pm 0,5\%$ of full scale.
- In-situ self-diagnosis.
- Alarm functions.
- Fast (adjustable) response controller.
- Single rail power supply +15...+24 Vdc.

SOFTWARE SUPPORT

Bronkhorst Hi-Tec offers free software support for personal computer or PLC.

- FlowDDE: Software tool to interface between digital instruments and windows software.
- FlowPlot: Software tool for monitoring and optimizing digital instruments parameters.
- FlowView: Software tool to operate Bronkhorst digital instruments.
- FlowFix: Software tool for fieldbus connection of digital instruments.



EL-PRESS P-702C @digital PRESSURE CONTROLLER

TECHNICAL SPECIFICATIONS EL-PRESS

MEASUREMENT SYSTEM

ACCURACY (INCL. LINEARITY)	±0,5% of full scale
REPEATABILITY	<0,1% of full scale
RESPONSE TIME SENSOR	<0,1 s.
CONTROL STABILITY	< ±0,1% full scale (typical for 1 l _n /min N ₂ at specified process volume)
ATTITUDE SENSITIVITY	max. error 0.015% at 1 bar N ₂ and 90° change
TEMPERATURE SENSITIVITY	0,1% of full scale/°C
SUPPLY VOLTAGE SENSITIVITY	zero at correct supply voltages (acc. to electr. data)
LEAK INTEGRITY (SEE SEMI E 18-91)	tested < 2 x 10 ⁻⁹ mbar l/s He Additional pressure test at 1,5 times the max. stated operating pressure
RFI	CE approved design

MECHANICAL PARTS

PROCESS CONNECTIONS	see model number code; other on application
MATERIALS OF CONSTRUCTION	stainless steel AISI 316L or comparable
SEALS	Viton, EPDM, elast. PTFE, other on application
SURFACE QUALITY	Ra 0,2...0,6 µm

OPERATING LIMITS

PRESSURE RANGEABILITY	Measurement 1 : 50
	Control (with flow range 1 : 50)
	P-602C/P-612C 1 : 20
	P-702C/P-712C 1 : 5
	P-500 series with separate control valve up to 1 : 50 (depending on application)
TYPES OF GASES OR LIQUIDS	all fluids compatible with AISI 316L
TEMPERATURE	-10 °C up to +70 °C
WARMING-UP TIME	30 min for optimum accuracy, 2 min for accuracy ±2% of full scale

ELECTRICAL PROPERTIES

SUPPLY VOLTAGE	analog EPT: +15 V, 45 mA -15 V, 20 mA or +15 V, 45 mA or +24 V, 45 mA
	EPC: +15 V, 225...300 mA -15 V, 20 mA or +15 V, 300 mA or +24 V, 230 mA
	digital EPT: +15 V, 95...115 mA or +24 V, 70...90 mA
	EPC: +15 V, 235...385 mA or +24 V, 150...240 mA
OUTPUT SIGNAL (SHORT CIRCUIT PROTECTED)	analog: 0...5 V, 0...10 V, min. load impedance > 2 kOhm 0 (4)...20 mA, max. load impedance < 375 Ohm
	digital: RS-232, FLOW-BUS, Profibus-DP or Devicenet
SETPOINT SIGNAL	analog: 0 (1)...5 V, 0...10 V, input resistance min. 1 MOhm 0(4)...20 mA, input resistance 250 Ohm
REFERENCE SIGNAL	analog: 5 V (10 V), min. load impedance > 2 kOhm
ELECTRICAL CONNECTION	analog/RS-232: male, 9-pin sub-D connector
	digital: female, RJ45, 9-pin sub-D or M12 (depending on fieldbus)

■ CALIBRATION

The calibration is done with equipment certified by the Netherlands Measurement Institute (NMI) and is in accordance with European and most important other countries' regulations.

■ CONFIGURATIONS

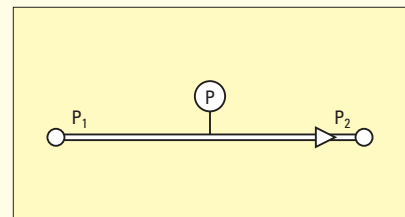

PRESSURE MEASUREMENT

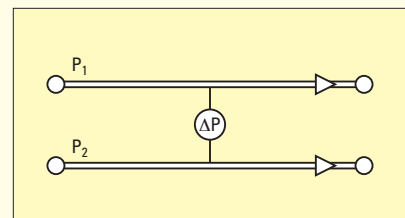

ΔP-MEASUREMENT

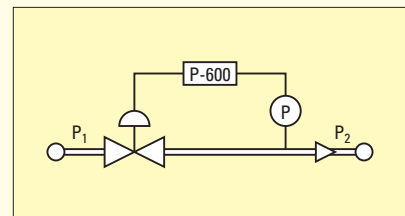

FORWARD PRESSURE CONTROL

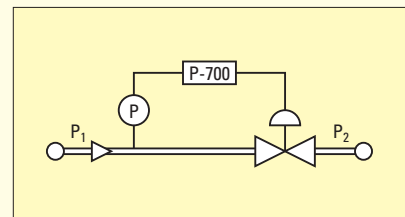

BACK PRESSURE CONTROL

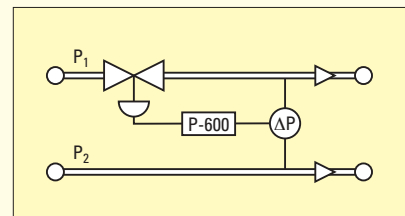

ΔP-CONTROL

CONTROL VALVES

The control valve can be supplied as an integral part of an EL-PRESS pressure controller, or as a separate component. It is a proportional, electro magnetic control valve with extremely fast and smooth flow control characteristics.

With reference to the specific fields of application there are different series of Bronkhorst Hi-Tec control valves. The optimum choice is made together with your distributor after having studied the operating conditions and requirements. But for those of you that want detailed information, the most important features of the various models are summarised here (see also the graph printed below).

GRAPHIC DISPLAY OF K_V AND MAX. PRESSURE

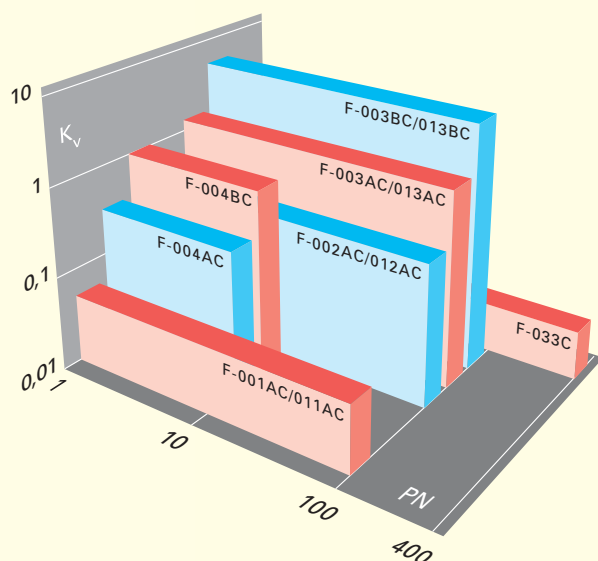

PRINCIPLE OF OPERATION

In the neutral position (no valve voltage supply), the control mechanism, a plunger/orifice system, is closed by means of a spring and the differential pressure. As soon as the controller supplies sufficient voltage, the magnetic force caused by the coil lifts the plunger, until the forces are in balance and the desired gas flow rate is maintained. The valve is normally closed. In the normally opened version the plunger/orifice control mechanism is closed by the ΔP and the magnetic force.

SUMMARY OF TYPES AND MODELS

Type	Model	K_V max.	ΔP min.	ΔP max.	PN
Direct acting	F-001AC, F-011AC	$6,6 \times 10^{-2}$	-	3,6...50 bar*	100
Vary-P	F-033C	$5,1 \times 10^{-2}$	6 bar	400 bar	400
Pilot-operated	F-002AC, F-012AC	0,4	1,3 bar	20 bar	100
	F-003AC, F-013AC	1,5	1,6 bar	20 bar	100
	F-003BC, F-013BC	6,0	1,6 bar	20 bar	100
Bellows	F-004AC	0,3	-	5 bar	10
	F-004BC	1,0	-	5 bar	10

* depending on K_V -value.



ADVANTAGES

- Modular
- Compact
- Simple
- Electro-chemically polished
- User replaceable

DIRECT ACTING VALVE F-001AC

The valve consists of a valve module (see picture) that is mounted onto a base block. The base block may constitute a separate control valve F-001AC, or an EPC (P-602C, P-702C). The valve module is also used as pilot valve in bigger valves and controllers.

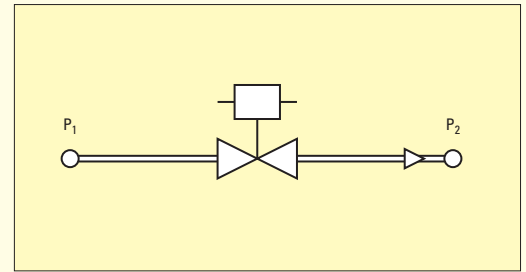

VARY-P VALVE F-033C

This is a patented 2-phase control valve. The flow control section is the valve module as described above. The other section is a pressure compensation valve; the latter maintains a constant ΔP across the first section ($P_1 - P'_1$) of 4 bar. By doing so both the inlet pressure P_1 and the outlet pressure P_2 may change without having any impact on the Vary-P Valve function.

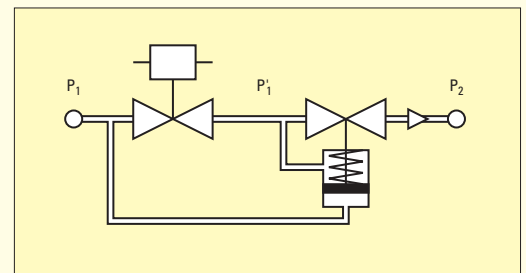

PILOT-OPERATED VALVES F-002AC, F-003AC, F-003BC

Are patented indirect acting control valves and use a complete Vary-P Valve as described above, as pilot valve. Hence they are also pressure compensated. The pilot controls the pressure on the back side of a spring loaded cylinder, of which the front side is subject to the inlet pressure of the main valve. This cylinder furnishes the power for the main valve. As soon as the ΔP becomes bigger than the spring force, the main valve, will open.

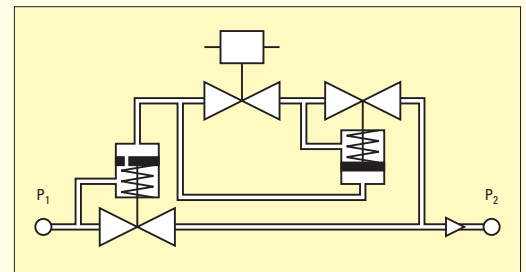

PRESSURE COMPENSATED BELLOW VALVES F-004AC/F-004BC

Are direct acting control valves as the above-mentioned F-001AC series. They are also closed by spring force. A bellows compensates the closing force acting on the plunger to such a degree that only a very small magnetic force is required and in this way large orifices can be opened, which is impossible in the F-001AC design as it would cause oscillation. The bellows pressure compensated design, however, enables us to smoothly control large flows at extremely low pressures.

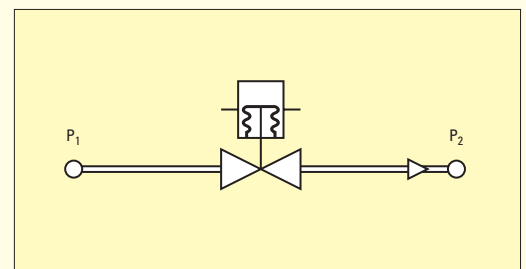

MODEL NUMBER IDENTIFICATION

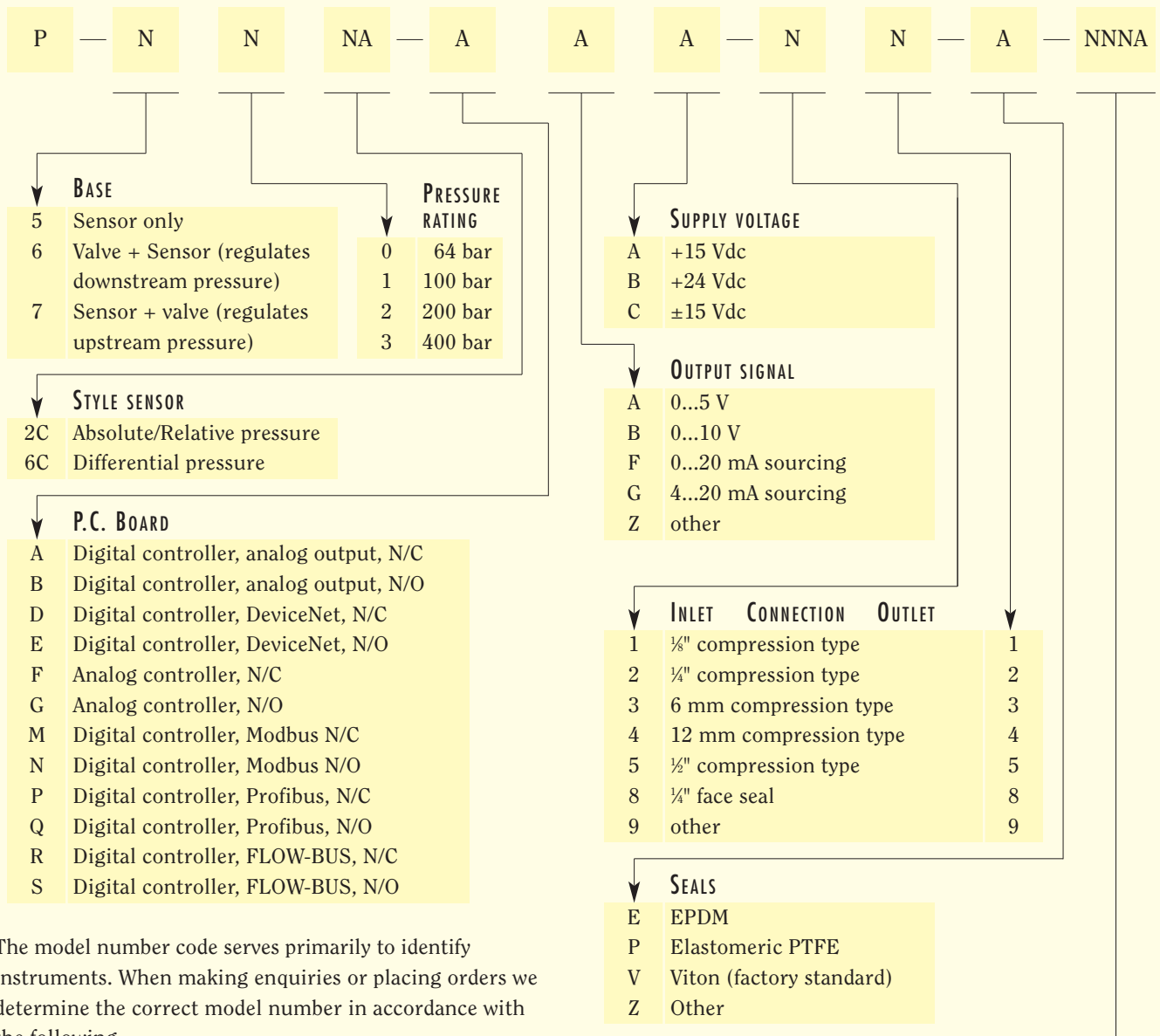

The model number code serves primarily to identify instruments. When making enquiries or placing orders we determine the correct model number in accordance with the following

ENQUIRY AND ORDERING INFORMATION

In order to furnish the optimum instrument for your application we request you to state: operating pressure (for controllers upstream and downstream pressure and also the process volume), type of gas or liquid, flow and operating temperature, electrical connection, desired output signal, type of process connection and seals.

Based on this information we perform the following actions/calculations:

- Determination of the pressure range to be measured or controlled.
- Only for controllers, check if the pressure differential across the valve (ΔP) is within the limits.
- Only for controllers, check if the FLUIDAT calculated K_v -value is within the specifications allowed.

	Absolute pressure	Relative pressure**
00A1	100...200 mbara	00R1 100...200 mbarg
002A	0,2...1,2 bara	002R 0,2...1 barg
005A	1,2...4 bara	004R 1...4 barg
020A	4...15 bara	020R 4...15 barg
100A	15...100 bara	
400A	100...400 bara	

** for relative pressure ranges higher than 15 barg an absolute sensor is used

	Differential pressure
00D1	100...200 mbard
002D	0,2...1 bard
005D	1...4 bard
020D	4...15 bard

EXAMPLES OF SOME APPLICATIONS

It is of course impossible to picture the possible number of applications. Here is a limited quantity of basic examples, which are often seen with some variations. However, identical or similar configurations are used in totally different applications. Therefore please consider the ones pictured here as examples for solving common applications.

BACK PRESSURE CONTROL INDEPENDENT OF GAS MIX AND TOTAL FLOW

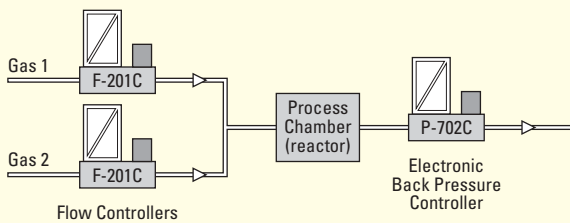

A gas mixture is formed by EL-FLOW Mass Flow Controllers. In a process chamber the effect of the catalyst on certain reactions is tested. The pressure in the process chamber is controlled to the desired level by means of an EL-PRESS Back Pressure Controller, independent of the total flow and/or the composition of the mixture.

PRESSURE CONTROL WITH ADJUSTABLE FLOW

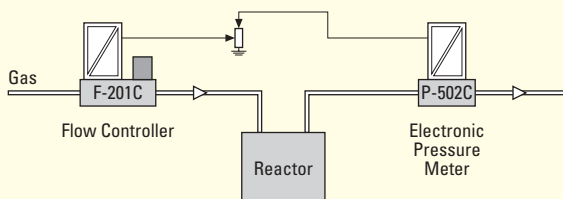

The control valve of the EL-FLOW F-201C Mass Flow Controller (MFC) forms a closed loop pressure control system with the EL-PRESS P-502C Pressure Transducer: the Mass Flow Meter of the MFC measures the required flow rate to maintain the set pressure level. The setpoint voltage divider enables the user to adjust the maximum flow to build up desired pressure levels. Restriction of the maximum flow may for safety reasons be important in certain processes.

PRESSURE CONTROL COMBINED WITH FLOW MEASUREMENT

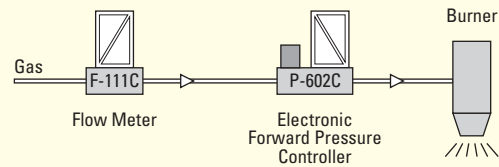

This arrangement of an EL-FLOW Mass Flow Meter with, in series, an EL-PRESS Forward Pressure Controller is used in burner test applications, or tests to check the inlet pressure dependence of the capacity of mechanical pressure regulators, or the tolerance on the bore of orifices, etc.

FORWARD PRESSURE CONTROL IN G.C. (GAS CHROMATOGRAPHY)

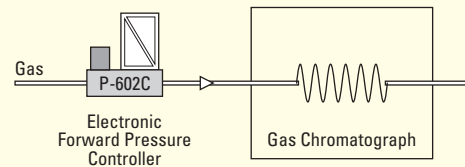

In Gas-Chromatography there is an increasing need to automate all required parameters. The EL-PRESS Forward Pressure Controller enables the user to select a desired pressure profile for the analyses, whereby the pressure is kept constant to a very precise value, even at very low flow rates.

COMPENSATION OF ATMOSPHERIC PRESSURE CHANGES

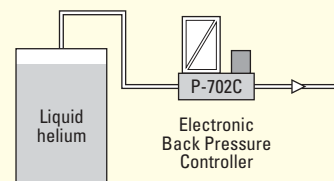

Superconducting coils, which are used to generate magnetic fields, are cooled by liquid helium. Depending on the temperature exchange gaseous helium should be vented. With a manually controlled outlet the variation of the atmospheric pressure disturbs the magnetic field. By using an EL-PRESS P-702C Back Pressure Controller the pressure for the superconducting coils is kept constant, thus eliminating the negative effects of atmospheric pressure variations.

READOUT SYSTEMS WITH INTEGRATED POWER SUPPLY

THE WIDE SELECTION IN READOUT SYSTEMS

Bronkhorst High-Tech offers a wide range of single- and multi-channel systems, using both digital and analog operation

The readout systems make much more possible than providing command signals to a number of controllers, for instance for making defined gas mixtures. The parameter to be controlled by the flowrate can also be temperature, process pressure, pH-value, and the command signals for these can be directly provided to the flow control loop. In combination with computers or PLCs ramp functions or other programmable process phases can be realised .

This brochure does not lend itself to show all the possibilities how to build control systems; your local distributor will gladly discuss your particular application with you in detail.

FLOW-BUS SINGLE-CHANNEL MODULE

Series E-7000

The digital single-channel control module was developed by Bronkhorst High-Tech B.V. for mass flow and pressure measurement and control systems. Its application is not limited to operation in combination with Bronkhorst Hi-Tec mass flow controllers and pressure controllers, but it can also be used with other transmitters or transducers, or in master/slave control systems.

The Bronkhorst Hi-Tec FLOW-BUS Series E-7000 offers the user a menu driven device with the possibility to define and control mass flow meters/controllers, pressure transducers/controllers or other instruments.

The μ -processor based single-channel module offers the possibility to show tag numbers, measurement identifications, fluid names and totalizing units on top of the measurement and command signals in percent of max. flow or direct reading units.

In addition there is the feature to program up to eight polynomial functions of calibration curves to achieve an accuracy of $\pm 0,5\%$ of the measured value plus $\pm 0,1\%$ of full scale.



E-7000 SINGLE CHANNEL MODULE

FEATURES

A user-friendly Indication/Control/Alarm/Totalization module, menu driven with 5 push buttons for:

- Use with digital or analog instruments,
- Indication of measured value on a 2-line, 16-figure display in percent or direct indication, combined with totalized quantity or preset quantity,
- Internal/external command,
- Master/Slave control,
- Totalization or batch functions,
- Programmable alarm functions,
- NO/NC relays for status outputs,
- Programming of max. 8 polynomial functions.

■ FLOW-BUS MULTI-CHANNEL CONFIGURATIONS

Based on the single-channel module it is easy to form multi-channel units. Three channels fit in a ½ 19" housing and six channels can be housed in a 19" table top or rack mounting unit.

Specifications

Housing:

- Cassette for panel mounting (1 channel) 96 x 144 mm.
- Table top housing (1 channel) 76 x 134 x 260 mm.
- Table top or rack housing (max. 3 channels)
3 HE ½ 19"
- Table top or rack housing (max. 6 channels)
3 HE 19"

Electrical data

- Power supply 100...240 Vac, 50...60 Hz or 24 Vac/Vdc.,
- Output signals/command signals 0...5 (10) Vdc,
0 (4)...20 mA,
- Sub-D Connector for instrument connection,
- Sub-D Connector for analog I/O functions,
- RJ 45 Connector for connection to FLOW-BUS,
- Max. power output +15 Vdc 1,5 A,
-15 Vdc 150 mA.

■ FLOW-BUS DIGITAL READOUT SYSTEM

Series E-7002

This series comprises modular readout systems built up from E-5700 and E-7000 modules.

Tailer-made systems with non-standard functions are also included in this series.



E-7100 3-CHANNEL EXECUTION

READOUT SYSTEMS WITH INTEGRAL POWER SUPPLY

ANALOG STANDARD READOUTS

Series E-5700

This series comprises standardised models for use with analog Mass Flow and Pressure Meters/Controllers for common basic requirements.

It is a simple, low cost unit for users who do not require the advanced features of the FLOW-BUS Series.

- E-5752: 2-channel system, table top model
- E-5762: 2-channel system, panel mount (96 x 144 mm)
- E-5712: 2-channel system, ½ 19" table top model
- E-5732: 2-channel system, ½ 19" for rack mounting
- E-5714: 4-channel system, ½ 19" table top model
- E-5734: 4-channel system, ½ 19" for rack mounting
- E-5716: 6-channel system, ½ 19" table top model
- E-5736: 6-channel system, ½ 19" for rack mounting

Functions

- 1 Indicator per 2 channels, with selector switch,
- 1 Command potentiometer per channel,
- 1 Internal/external command signal switch,
- 100...240 Vdc power supply.



E-5752 2-CHANNEL PS/READOUT



E-5736 6-CHANNEL PS/READOUT

Electrical data

- Power supply 100...240 Vac
- Suitable for connection of instruments with output signal 0..5 (10) Vdc.
- Ext. output and/or setpoint signals: 0...5 (10) Vdc; 0 (4) ...20 mA (to be advised).
- Sub-D socket for instrument connection.
- Sub-D socket for analog I/O function.
- Max. power output +15 Vdc, 2 A / -15 Vdc, 300 mA.

OTHER BRONKHORST HI-TEC PRODUCTS

In addition to the instruments of the EL-PRESS series described in this catalogue we would like to show some other product groups within our range of instruments. Separate brochures for these are available on request from your distributor.



EL-FLOW®

Mass flow meters and controllers for gases with an electronic housing suitable for laboratory conditions.

Instruments of the EL-FLOW® series are the only ones on the market that can control flow ranges between 0...1 ml_n/min and 0...1250 l_n/min between vacuum and 400 bar in one

range of instruments. The particular versatility in flow ranges and in operating conditions have made EL-FLOW® the best sold and proven instrument series.



EX-FLOW

Mass flow meters and controllers for gases in rugged construction with approval for use in hazardous areas.

The measuring ranges are from 0,15...7,5 ml_n/min up to 220...11.000 m³_n/h. The mass flow meter has ATEX approval according to II 2 G EEx ib II C T4.

The electronic housing is IP65. The control valves have Kv-values between 5,7 x 10⁻⁵ and 6,0 and approvals to ATEX II 2 G/D IP6X T 130°C EEx me II T4 and II 1 G/D EEx ia IIC T6



IN-FLOW

Mass Flow Meters and Controllers for gases suitable for applications in industrial environments, due to their IP 65 protection. Not only can the

EL-FLOW® and LOW-ΔP-FLOW series be supplied in this way, but moreover instruments can be supplied suitable up to 11.000 m³_n/h as described in the IN-FLOW brochure.



LIQUI-FLOW®

Mass Flow Meters and Controllers for liquids in ranges between 0,1...5 g/h and 0,4...20 kg/h (water equivalent). LIQUI-FLOW® flow meters only require a small differential pressure.

In spite of measurement without a by-pass the rise in temperature of the fluid is minimal; only approx.

1...5 °C. This greatly limits the danger of evaporation or degradation of the fluid. For even smaller ranges Bronkhorst High-Tech offers the μ-FLOW series; smallest range: 1,5...30 mg/h (water equivalent).

If one or more instruments described here are of interest to you, then please do not hesitate to contact your distributor.



Nijverheidsstraat 1a, 7261 AK Ruurlo, The Netherlands

Tel.: +31 573 458800, telefax: +31 573 458808

Internet: www.bronkhorst.com, E-mail: sales@bronkhorst.com

Distr.:

E.EPB.0205.F