

Surveyor MS Pump & Surveyor MS Pump Plus

Hardware Manual

60053-97105 Revision D January 2009

DOCUMENTATION
SURVEY

© 2009 Thermo Fisher Scientific Inc. All rights reserved.

Xcalibur is a registered trademark and Surveyor is a trademark of Thermo Fisher Scientific Inc in the United States.

Super Flangeless is a trademark of Upchurch Scientific.

The following are registered trademarks in the United States and other countries: Windows is a registered trademark of Microsoft Corporation. Teflon is a registered trademark of E. I. du Pont de Nemours & Co.

Thermo Fisher Scientific Inc. provides this document to its customers with a product purchase to use in the product operation. This document is copyright protected and any reproduction of the whole or any part of this document is strictly prohibited, except with the written authorization of Thermo Fisher Scientific Inc.

The contents of this document are subject to change without notice. All technical information in this document is for reference purposes only. System configurations and specifications in this document supersede all previous information received by the purchaser.

Thermo Fisher Scientific Inc. makes no representations that this document is complete, accurate or error-free and assumes no responsibility and will not be liable for any errors, omissions, damage or loss that might result from any use of this document, even if the information in the document is followed properly.

This document is not part of any sales contract between Thermo Fisher Scientific Inc. and a purchaser. This document shall in no way govern or modify any Terms and Conditions of Sale, which Terms and Conditions of Sale shall govern all conflicting information between the two documents.

Release history: Revision A April 2005. Revision B April 2006. Revision C September 2006. Revision D January 2009.

For Research Use Only. Not regulated for medical or veterinary diagnostic use by U.S. Federal Drug Administration or other competent authorities.



Regulatory Compliance

Thermo Fisher Scientific performs complete testing and evaluation of its products to ensure full compliance with applicable domestic and international regulations. When the system is delivered to you, it meets all pertinent electromagnetic compatibility (EMC) and safety standards as described in the next section by product name.

Changes that you make to your system might void compliance with one or more of these EMC and safety standards. Changes to your system include replacing a part or adding components, options, or peripherals not specifically authorized and qualified by Thermo Fisher Scientific. To ensure continued compliance with EMC and safety standards, replacement parts and additional components, options, and peripherals must be ordered from Thermo Fisher Scientific or one of its authorized representatives.

Surveyor MS Pump Plus

EMC Directive 89/336/EEC amended by 92/31/EEC and 93/68/EEC

EMC compliance has been evaluated by Underwriters Laboratories Inc.

EN 55011	1998	EN 61000-4-3	2002
EN 61000-3-2	1995, A1; 1998, A2; 1998, A14; 2000	EN 61000-4-4	1995, A1; 2001, A2; 2001
IEC 61000-3-2	2000	EN 61000-4-5	1995, A1; 2001
EN 61000-3-3	1995	EN 61000-4-6	1996, A1; 2001
IEC 61000-3-3	1994	EN 61000-4-11	1994, A1; 2001
EN 61326-1	1997		
EN 61000-4-2	1995 A1; 1998 A2; 2001	CISPR 11	1999, A1; 1999, A2; 2002
FCC Class A, CFR 47 Part 15 Subpart B: 2003			

Low Voltage Safety Compliance

This device complies with Low Voltage Directive 73/23/EEC and harmonized standard EN 61010-1:2001.

FCC Compliance Statement

THIS DEVICE COMPLIES WITH PART 15 OF THE FCC RULES. OPERATION IS SUBJECT TO THE FOLLOWING TWO CONDITIONS: (1) THIS DEVICE MAY NOT CAUSE HARMFUL INTERFERENCE, AND (2) THIS DEVICE MUST ACCEPT ANY INTERFERENCE RECEIVED, INCLUDING INTERFERENCE THAT MAY CAUSE UNDESIRE OPERATION.



CAUTION Read and understand the various precautionary notes, signs, and symbols contained inside this manual pertaining to the safe use and operation of this product before using the device.

Notice on Lifting and Handling of Thermo Scientific Instruments

For your safety, and in compliance with international regulations, the physical handling of this Thermo Fisher Scientific instrument *requires a team effort* to lift and/or move the instrument. This instrument is too heavy and/or bulky for one person alone to handle safely.

Notice on the Proper Use of Thermo Scientific Instruments

In compliance with international regulations: Use of this instrument in a manner not specified by Thermo Fisher Scientific could impair any protection provided by the instrument.

Notice on the Susceptibility to Electromagnetic Transmissions

Your instrument is designed to work in a controlled electromagnetic environment. Do not use radio frequency transmitters, such as mobile phones, in close proximity to the instrument.

For manufacturing location, see the label on the instrument.

WEEE Compliance

This product is required to comply with the European Union's Waste Electrical & Electronic Equipment (WEEE) Directive 2002/96/EC. It is marked with the following symbol:



Thermo Fisher Scientific has contracted with one or more recycling or disposal companies in each European Union (EU) Member State, and these companies should dispose of or recycle this product. See www.thermo.com/WEEERoHS for further information on Thermo Fisher Scientific's compliance with these Directives and the recyclers in your country.

WEEE Konformität

Dieses Produkt muss die EU Waste Electrical & Electronic Equipment (WEEE) Richtlinie 2002/96/EC erfüllen. Das Produkt ist durch folgendes Symbol gekennzeichnet:









Thermo Fisher Scientific hat Vereinbarungen mit Verwertungs-/Entsorgungsfirmen in allen EU-Mitgliedsstaaten getroffen, damit dieses Produkt durch diese Firmen wiederverwertet oder entsorgt werden kann. Mehr Information über die Einhaltung dieser Anweisungen durch Thermo Fisher Scientific, über die Verwerter, und weitere Hinweise, die nützlich sind, um die Produkte zu identifizieren, die unter diese RoHS Anweisung fallen, finden sie unter www.thermo.com/WEEERoHS.

Conformité DEEE

Ce produit doit être conforme à la directive européenne (2002/96/EC) des Déchets d'Equipements Electriques et Electroniques (DEEE). Il est marqué par le symbole suivant:

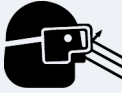

Thermo Fisher Scientific s'est associé avec une ou plusieurs compagnies de recyclage dans chaque état membre de l'union européenne et ce produit devrait être collecté ou recyclé par celles-ci. Davantage d'informations sur la conformité de Thermo Fisher Scientific à ces directives, les recycleurs dans votre pays et les informations sur les produits Thermo Fisher Scientific qui peuvent aider la détection des substances sujettes à la directive RoHS sont disponibles sur www.thermo.com/WEEERoHS.

CAUTION Symbol	CAUTION	VORSICHT	ATTENTION	PRECAUCION	AVVERTENZA
	Electric Shock: This instrument uses high voltages that can cause personal injury. Before servicing, shut down the instrument and disconnect the instrument from line power. Keep the top cover on while operating the instrument. Do not remove protective covers from PCBs.	Elektroschock: In diesem Gerät werden Hochspannungen verwendet, die Verletzungen verursachen können. Vor Wartungsarbeiten muß das Gerät abgeschaltet und vom Netz getrennt werden. Betreiben Sie Wartungsarbeiten nicht mit abgenommenem Deckel. Nehmen Sie die Schutzabdeckung von Leiterplatten nicht ab.	Choc électrique: L'instrument utilise des tensions capables d'infliger des blessures corporelles. L'instrument doit être arrêté et débranché de la source de courant avant tout intervention. Ne pas utiliser l'instrument sans son couvercle. Ne pas enlever les étuis protecteurs des cartes de circuits imprimés.	Descarga eléctrica: Este instrumento utiliza altas tensiones, capaces de producir lesiones personales. Antes de dar servicio de mantenimiento al instrumento, éste deberá apagarse y desconectarse de la línea de alimentación eléctrica. No opere el instrumento sin sus cubiertas exteriores quitadas. No remueva las cubiertas protectoras de las tarjetas de circuito impreso.	Shock da folgorazione. L'apparecchio è alimentato da corrente ad alta tensione che può provocare lesioni fisiche. Prima di effettuare qualsiasi intervento di manutenzione occorre spegnere ed isolare l'apparecchio dalla linea elettrica. Non attivare lo strumento senza lo schermo superiore. Non togliere i coperchi a protezione dalle schede di circuito stampato (PCB).
	Chemical: This instrument might contain hazardous chemicals. Wear gloves when handling toxic, carcinogenic, mutagenic, or corrosive or irritant chemicals. Use approved containers and proper procedures to dispose waste oil.	Chemikalien: Dieses Gerät kann gefährliche Chemikalien enthalten. Tragen Sie Schutzhandschuhe beim Umgang mit toxischen, karzinogenen, mutagenen oder ätzenden/reizenden Chemikalien. Entsorgen Sie verbrauchtes Öl entsprechend den Vorschriften in den vorgeschriebenen Behältern.	Chimique: Des produits chimiques dangereux peuvent se trouver dans l'instrument. Portez des gants pour manipuler tous produits chimiques toxiques, cancérigènes, mutagènes, ou corrosifs/irritants. Utilisez des récipients et des procédures homologuées pour se débarrasser des déchets d'huile.	Química: El instrumento puede contener productos químicos peligrosos. Utilice guantes al manejar productos químicos tóxicos, carcinogénos, mutagénos o corrosivos/irritantes. Utilice recipientes y procedimientos aprobados para deshacerse del aceite usado.	Prodotti chimici. Possibile presenza di sostanze chimiche pericolose nell'apparecchio. Indossare dei guanti per maneggiare prodotti chimici tossici, cancerogeni, mutageni, o corrosivi/irritanti. Utilizzare contenitori aprovo e seguire la procedura indicata per lo smaltimento dei residui di olio.
	Heat: Before servicing the instrument, allow any heated components to cool.	Hitze: Warten Sie erhitzte Komponenten erst nachdem diese sich abgekühlt haben.	Haute Temperature: Permettre aux composants chauffés de refroidir avant tout intervention.	Altas temperaturas: Permita que los componentes se enfríen, ante de efectuar servicio de mantenimiento.	Calore. Attendere che i componenti riscaldati si raffreddino prima di effettuare l'intervento di manutenzione.
	Fire: Use care when operating the system in the presence of flammable gases.	Feuer: Beachten Sie die einschlägigen Vorsichtsmaßnahmen, wenn Sie das System in Gegenwart von entzündbaren Gasen betreiben.	Incendie: Agir avec précaution lors de l'utilisation du système en présence de gaz inflammables.	Fuego: Tenga cuidado al operar el sistema en presencia de gases inflamables.	Incendio. Adottare le dovute precauzioni quando si usa il sistema in presenza di gas infiammabili.
	Eye Hazard: Eye damage could occur from splattered chemicals or flying particles. Wear safety glasses when handling chemicals or servicing the instrument.	Verletzungsgefahr der Augen: Verspritzte Chemikalien oder kleine Partikel können Augenverletzungen verursachen. Tragen Sie beim Umgang mit Chemikalien oder bei der Wartung des Gerätes eine Schutzbrille.	Danger pour les yeux: Des projections chimiques, liquides, ou solides peuvent être dangereuses pour les yeux. Porter des lunettes de protection lors de toute manipulation de produit chimique ou pour toute intervention sur l'instrument.	Peligro par los ojos: Las salicaduras de productos químicos o partículas que saltan bruscamente pueden causar lesiones en los ojos. Utilice anteojos protectores al manipular productos químicos o al darle servicio de mantenimiento al instrumento.	Pericolo per la vista. Gli schizzi di prodotti chimici o delle particelle presenti nell'aria potrebbero causare danni alla vista. Indossare occhiali protettivi quando si maneggiano prodotti chimici o si effettuano interventi di manutenzione sull'apparecchio.
	General Hazard: A hazard is present that is not included in the above categories. Also, this symbol appears on the instrument to refer the user to instructions in this manual. When the safety of a procedure is questionable, contact your local Technical Support organization for Thermo Fisher Scientific San Jose Products.	Allgemeine Gefahr: Es besteht eine weitere Gefahr, die nicht in den vorstehenden Kategorien beschrieben ist. Dieses Symbol wird im Handbuch außerdem dazu verwendet, um den Benutzer auf Anweisungen hinzuweisen. Wenn Sie sich über die Sicherheit eines Verfahrens im unklaren sind, setzen Sie sich, bevor Sie fortfahren, mit Ihrer lokalen technischen Unterstützungsorganisation für Thermo Fisher Scientific San Jose Produkte in Verbindung.	Danger général: Indique la présence d'un risque n'appartenant pas aux catégories citées plus haut. Ce symbole figure également sur l'instrument pour renvoyer l'utilisateur aux instructions du présent manuel. Si la sûreté d'un procédé est incertaine, avant de continuer, contacter le plus proche Service Clientèle pour les produits de Thermo Fisher Scientific San Jose.	Peligro general: Significa que existe un peligro no incluido en las categorías anteriores. Este símbolo también se utiliza en el instrumento para referir al usuario a las instrucciones contenidas en este manual. Cuando la certidumbre acerca de un procedimiento sea dudosa, antes de proseguir, pongase en contacto con la Oficina de Asistencia Técnica local para los productos de Thermo Fisher Scientific San Jose.	Pericolo generico. Pericolo non compreso tra le precedenti categorie. Questo simbolo è utilizzato inoltre sull'apparecchio per segnalare all'utente di consultare le istruzioni descritte nel presente manuale. Quando è in dubbio la misura di sicurezza per una procedura, prima di continuare, si prega di mettersi in contatto con il Servizio di Assistenza Tecnica locale per i prodotti di Thermo Fisher Scientific San Jose.

CAUTION Symbol

CAUTION

危険警告

危險警告



Electric Shock: This instrument uses high voltages that can cause personal injury. Before servicing, shut down the instrument and disconnect the instrument from line power. Keep the top cover on while operating the instrument. Do not remove protective covers from PCBs.

電撃: この計測器は高電圧を使用し、人体に危害を与える可能性があります。保守・修理は、必ず作業を停止し、電源を切ってから実施して下さい。上部カバーを外したままで計測器を使用しないで下さい。プリント配線板の保護カバーは外さないで下さい。

電撃: 儀器設備使用會造成人身傷害的高伏電壓。在維修之前，必須先關儀器設備並切除電源。務必要在頂蓋蓋上的情況下操作儀器。請勿拆除PCB保護蓋。



Chemical: This instrument might contain hazardous chemicals. Wear gloves when handling toxic, carcinogenic, mutagenic, or corrosive or irritant chemicals. Use approved containers and proper procedures to dispose waste oil.

化学物質: 危険な化学物質が計測器中に存在している可能性があります。毒性、発がん性、突然変異性、腐食・刺激性などのある薬品を取り扱う際は、手袋を着用して下さい。廃油の処分には、規定の容器と手順を使用して下さい。

化学品: 儀器設備中可能存在有危險性的化學物品。接觸毒性致癌、誘變或腐蝕/刺激性化學品時，請配帶手套。處置廢油時，請使用經過許可的容器和程序。



Heat: Before servicing the instrument, allow any heated components to cool.

熱: 熱くなった部品は冷えるのを待ってから保守・修理を行って下さい。

高温: 請先等高温零件冷卻之後再進行維修。



Fire: Use care when operating the system in the presence of flammable gases.

火災: 可燃性のガスが存在する場所でシステムを操作する場合は、充分な注意を払って下さい。

火災: 在有易燃氣體的場地操作該系統時，請務必小心謹慎。



Eye Hazard: Eye damage could occur from splattered chemicals or flying particles. Wear safety glasses when handling chemicals or servicing the instrument.

眼に対する危険: 化学物質や微粒子が飛散して眼を傷つける危険性があります。化学物質の取り扱い、あるいは計測器の保守・修理に際しては防護眼鏡を着用して下さい。

眼睛傷害危険: 飛濺の化学品或顆粒可能造成眼睛傷害。處理化學品或維儀器設備時請佩戴安全眼鏡。



General Hazard: A hazard is present that is not included in the above categories. Also, this symbol appears on the instrument to refer the user to instructions in this manual.

一般的な危険: この標識は上記以外のタイプの危険が存在することを示します。また、計測器にこの標識がついている場合は、本マニュアル中の指示を参照して下さい。

一般性危険: 説明未包括在上述類別中的其他危險。此外，儀器設備上使用這個標誌，以指示用戶本使用手冊中的說明。

When the safety of a procedure is questionable, contact your local Technical Support organization for Thermo Fisher Scientific San Jose Products.

安全を確保する手順がよくわからない時は、作業を一時中止し、お近くのサーモフィsherサンローゼプロダクトのテクニカルサポートセンターにご連絡ください。

如對安全程序有疑問，請在操作之前與當地的菲尼根技術服務中心聯繫。

Contents

	Preface	xi
	Related Documentationxi
	Safety and Special Noticesxi
	Good Laboratory Practices	xii
	Contacting Us	xiv
Chapter 1	Introduction	1
	Functional Description	2
	Vacuum Degasser Assembly	3
	Liquid Displacement Assembly	3
	Pulse Dampening Assembly	4
	Status LEDs	6
	Specifications	7
Chapter 2	Installation	9
	Installation Checklist	10
	Unpacking and Inspecting the Instrument	10
	Making the Initial Instrument Preparations	11
	Making the Initial Back Panel Connections	11
	Serial Communication Cable	12
	System Interconnect Cable	12
	Connecting the Low-Pressure Solvent Lines	15
	Step 1: Assembling the Solvent Reservoir Bottles	16
	Step 2: Installing the Super Flangeless Fittings	17
	Connecting the Pump to the Surveyor Autosampler Plus	19
	Powering On for the First Time	21
	Configuring the Data System PC COM Port	21
	Preparing the Pump for Operation	22
	Specifying the Instrument Configuration Options	22
	Purging Air from the Solvent Lines	25
	Priming the Pulse Dampener	26
Chapter 3	Diagnostics	29
	Monitoring Pump Pulsation	29
	Testing the Pump Proportioning	31
	Determining the Delay Volume of the Pump	33

Chapter 4	Maintenance	35
	Flushing the Piston Guide Bushings	36
	Purging Air from the Piston Chambers	37
	Cleaning the LDA Components without Disassembling the LDA	38
	Servicing the LDA	39
	Removing the LDA from the Pump	40
	Disassembling the LDA	43
	Cleaning the LDA Components	47
	Replacing the Primary Piston Seals	49
	Reassembling the LDA	51
	Reinstalling the LDA	60
	Servicing the Proportioning Valves	64
	Replacing the Solvent Reservoir Filter	65
Chapter 5	Troubleshooting	67
	Troubleshooting Tips	67
	General System Troubleshooting	68
	Surveyor MS Pump Troubleshooting Guide	70
	Pump Pulsation	72
	Normal Pressure Pulsation	73
	Abnormal Pressure Pulsation	73
	Baseline Noise at Low Pressures (under 40 Bar)	74
	Insufficient Solvent Flow from the Pump Outlet	74
	Pump Cavitation	75
	Blocked Proportioning Valve	75
	Blocked Check Valve	75
	Irreproducible Retention Times	76
Chapter 6	Accessories and Replacement Parts	77
	Liquid Displacement Assembly (LDA) Parts	78
	MS Pump Accessory Kit	80
	Solvent Interconnect Kit	80
	Other Parts and Assemblies	81
	Index	83

Preface

The Surveyor MS Pump and Surveyor MS Pump Plus are members of the Surveyor Plus™ family of LC instruments.

This *Surveyor MS Pump and Surveyor MS Pump Plus Hardware Manual* provides you with information on how to setup, maintain, and troubleshoot the Surveyor MS Pump and the Surveyor MS Pump Plus. A list of accessories and spare parts is also included. The Surveyor MS Pump and the Surveyor MS Pump Plus are operated from a computer running Xcalibur™ software (version 1.4 or higher).

Related Documentation

In addition to this guide, Thermo Fisher Scientific provides the following documents for the Surveyor MS Pump and the Surveyor MS Pump Plus:

- *Surveyor Plus Preinstallation Requirements Guide*
- *Surveyor Plus Getting Connected Guide*
- *Surveyor Plus Getting Started with Xcalibur Guide*

Safety and Special Notices

Make sure you follow the precautionary statements presented in this guide. The safety and other special notices appear in boxes.

Safety and special notices include the following:



CAUTION Highlights hazards to humans, property, or the environment. Each CAUTION notice is accompanied by an appropriate CAUTION symbol.

IMPORTANT Highlights information necessary to prevent damage to software, loss of data, or invalid test results; or might contain information that is critical for optimal performance of the system.

Note Highlights information of general interest.

Tip Helpful information that can make a task easier.

Good Laboratory Practices

To obtain optimal performance from your LC system and to prevent personal injury or injury to the environment, do the following:

- Keep good records.
- Read the manufacturers' Material Safety Data Sheets (MSDSs) for the chemicals being used in your laboratory.
- Remove particulate matter from your samples before you inject them into the liquid chromatograph.
- Use HPLC grade solvents.
- Connect the drainage tubes from the pump, autosampler, and detector to an appropriate waste receptacle. Dispose of solvents as specified by local regulations.

Keep Good Records

To help identify and isolate problems with either your equipment or your methodology, we recommend that you keep good records of all system conditions (for example, % RSDs on retention times and peak areas, peak shape and resolution). At a minimum, keep a chromatogram of a typical sample and standard mixture, well documented with system conditions, for future reference. Careful comparison of retention times, peak shapes, peak sensitivity, and baseline noise can provide valuable clues to identifying and solving future problems.

Chemical Toxicity

Although the large volume of toxic and flammable solvents used and stored in laboratories can be quite dangerous, do not ignore the potential hazards posed by your samples. Take special care to read and follow all precautions that ensure proper ventilation, storage, handling, and disposal of both solvents and samples. Become familiar with the toxicity data and potential hazards associated with all chemicals by referring to the manufacturers' Material Safety Data Sheets.

Sample Preparation

Always consider the solubility of your sample in the solvent/mobile phase. Sample precipitation can plug the column, tubing or flowcell causing flow restriction. This obstruction can result in irreparable damage to the system. Particulate matter can be avoided by filtering the samples through 0.45 or 0.2 micron (or less) filters.

Solvent Requirements

Many chemical manufacturers provide a line of high-purity or HPLC-grade reagents that are free of chemical impurities. Routine filtration of all solvents or eluents through a 0.45 or 0.2 micron (or less) fluorocarbon filter before placing them in the solvent reservoir significantly prolongs the life and effectiveness of the inlet filters, check valves and seals, injector, and column. Typically, HPLC-grade solvents do not require filtration.

Choose a mobile phase that is compatible with the sample and column you have selected for your separation. Remember that some solvents are corrosive to stainless steel.

Solvent Disposal

Make sure you have a solvent waste container or other kind of drain system available at or below the benchtop level. Most solvents have special disposal requirements and should not be disposed of directly down a drain. Follow all governmental regulations when disposing of any chemical.

High-pressure Systems and Leaks

LC systems operate at high pressures. Because liquids are not highly compressible they do not store much energy. Accordingly, there is little immediate danger from the high pressures in an LC system. However, if a leak occurs, it should be corrected as soon as possible. Always wear eye and skin protection when operating or maintaining an LC system. Always shut down the system and return it to atmospheric pressure before attempting any maintenance.

Contacting Us

There are several ways to contact Thermo Fisher Scientific for the information you need.

❖ **To contact Technical Support**

Phone	800-532-4752
Fax	561-688-8736
E-mail	us.techsupport.analyze@thermofisher.com
Knowledge base	www.thermokb.com

Find software updates and utilities to download at mssupport.thermo.com.

❖ **To contact Customer Service for ordering information**

Phone	800-532-4752
Fax	561-688-8731
E-mail	us.customer-support.analyze@thermofisher.com
Web site	www.thermo.com/ms

❖ **To copy manuals from the Internet**

Go to mssupport.thermo.com and click **Customer Manuals** in the left margin of the window.

❖ **To suggest changes to documentation or to Help**

- Click the link below. Thank you in advance for your help.



- Send an e-mail message to the Technical Publications Editor at techpubs-lcms@thermofisher.com.

Introduction

The Surveyor MS Pump and Surveyor MS Pump Plus are members of the Surveyor Plus™ family of LC instruments.

This chapter provides an introduction to the Surveyor MS Pump and Surveyor MS Pump Plus (see [Figure 1](#)).

Thermo Fisher Scientific no longer ships the Surveyor MS Pump, but this legacy version of the pump can be controlled with the new instrument control software provided on the LC Devices software CD. The information provided in this manual applies to both the Surveyor MS Pump and the Surveyor MS Pump Plus.

Contents

- [Functional Description](#)
- [Specifications](#)

Figure 1. Surveyor MS Pump Plus



Functional Description

The Surveyor MS Pump Plus is a quaternary, low-pressure mixing pump with built-in solvent degassing and pulse dampening systems. The pumping system provides optimum performance in the lower flow rate ranges needed for mass spectrometry. You can run precise gradients from 25 to 2000 $\mu\text{L}/\text{min}$. An extremely low gradient delay volume of 80 μL ensures minimum system cycle times. The integral vacuum degasser offers superb solvent degassing efficiency with less than 500 μL of volume, and the pulse dampener produces stable flow rates with only 3 μL of delay volume.

The Surveyor MS Pump Plus is a bench-top unit for inclusion in the Surveyor high performance liquid chromatograph (HPLC). It is remotely controlled by way of an RS232 serial communication link from a computer using Microsoft Windows NT-based Xcalibur software (version 1.3 or higher). The only manual control on the pump is a power switch.

The Surveyor MS Pump Plus (see [Figure 2](#)) has three major components: the vacuum degasser assembly, the liquid displacement assembly (LDA), and the pulse dampening assembly. In addition, the MS pump contains status LEDs, a low voltage power supply, and several printed circuit boards (PCBs).

Figure 2. Surveyor MS Pump Plus with the doors open, showing the major components

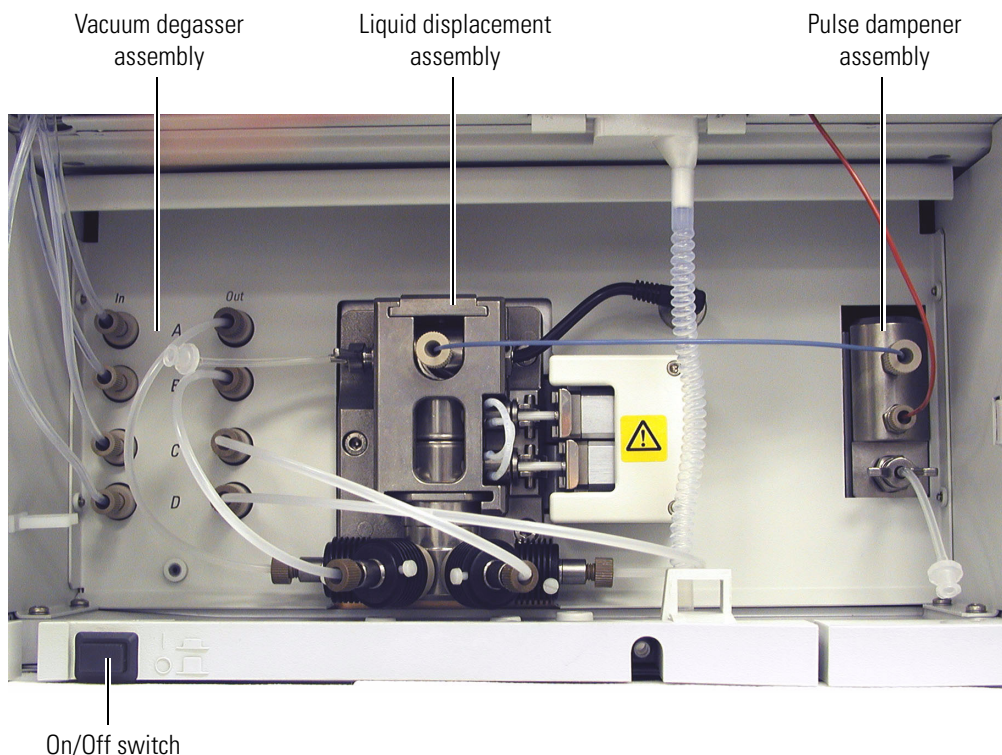

Vacuum Degasser Assembly

The Surveyor MS Pump Plus contains a built-in vacuum membrane degasser for the purpose of removing dissolved gasses from the mobile phase. Dissolved gasses can cause many problems in HPLC and must be kept to an absolute minimum for best performance. The MS pump solvent degassing system consists of four independent channels that are maintained at a constant vacuum of approximately 686 mm (27 in.) Hg. Each channel has a volume of less than 500 μL , which provides superior degassing efficiency capable of limiting dissolved oxygen to a level of only 0.8 ppm. The system's vacuum pump operates continuously, which eliminates the excess baseline noise and drift caused by vacuum pump cycling.

Liquid Displacement Assembly

The frame of the liquid displacement assembly (LDA) consists of two components: the LDA body and the inlet module. The LDA body contains the inlet and outlet check valves, two TZP-ceramic pistons and their seals, an upper and lower piston chamber, a pressure transducer, and various PTFE seal rings (see [Figure 75 on page 79](#)). The inlet module contains a built-in low volume mixer. Four high-precision proportioning valves are connected to the inlet module. And four actuating coils are connected to the ends of the proportioning valves. All of these components are integrated into a single mechanical-hydraulic assembly, which minimizes the pump's gradient delay volume to only 80 μL .

As the lower piston withdraws, mobile phase from the proportioning valve assembly passes through the inlet check valve and fills the lower piston chamber (see [Figure 75 on page 79](#)). As the lower piston returns, the inlet check valve closes and the mobile phase is pushed through the outlet check valve and into the upper piston chamber. Both check valves are low volume and incorporate a dual ball and seat design, which ensures a positive seal with minimal delay volume.

Next, the upper piston moves into the upper piston chamber, closing the outlet check valve and forcing the mobile phase into the pressure transducer housing. On the next piston stroke the mobile phase is pushed out of the LDA and into the crossover tube that is attached to the pulse dampening assembly.

The proportioning valves of the Surveyor MS Pump Plus incorporate a finely machined ball and seat design similar to a check valve. This ball and seat design controls the flow of solvents to a higher degree of precision and accuracy than the diaphragm design used by most gradient pumps. In addition, the ruby ball and sapphire seat are virtually wear free as opposed to the polymeric membrane of a diaphragm valve, which becomes more brittle and less responsive as it ages.

There is a venting valve on the left side of the LDA. When the venting valve is open, the mobile phase exits out the left end of the pressure sensor assembly. When the venting valve is closed, the mobile phase is directed out of the front of the pressure sensor assembly and into the crossover tube. [Figure 3](#) shows a pump with the venting valve in the open position for purging.

Figure 3. Purging air from the Surveyor MS Pump Plus

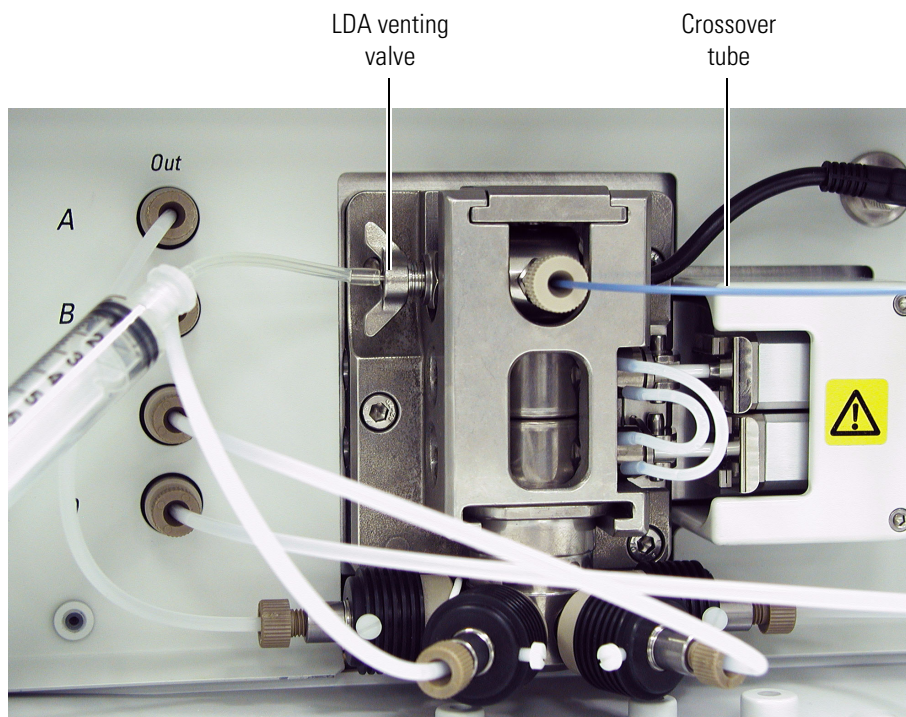

Pulse Dampening Assembly

The pulse dampening assembly is located on the right side of the Surveyor MS Pump Plus. See [Figure 4](#).

Figure 4. Front view of the pulse dampening assembly

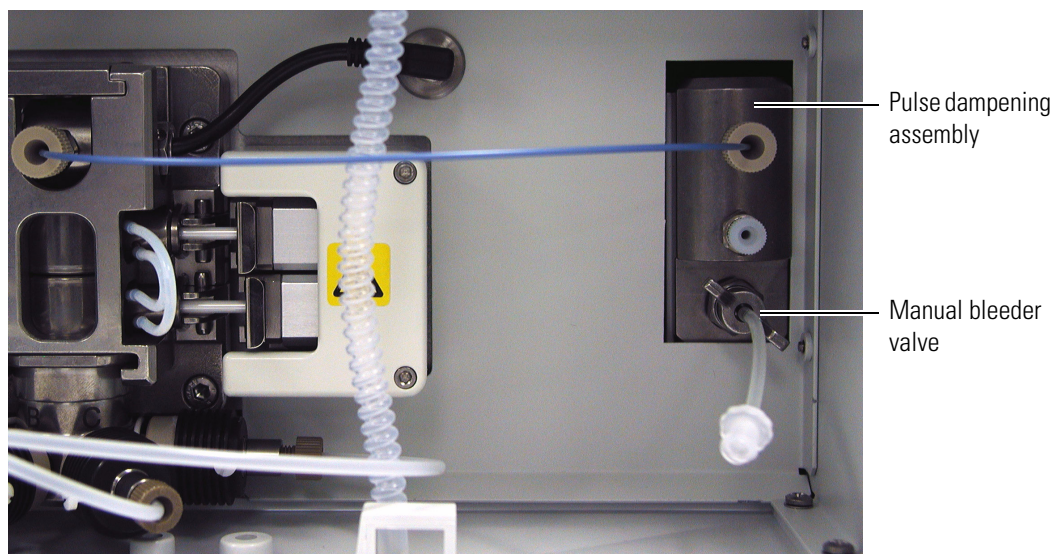

The pulse dampening assembly, built into the Surveyor MS Pump Plus, consists of a low volume T-connector through which the mobile phase passes. Attached to the side leg of the T-connector is a permeable isolation membrane made of sintered Teflon followed by a 2 mL loop of stainless steel tubing. See [Figure 5](#).

Figure 5. Pulse dampening assembly

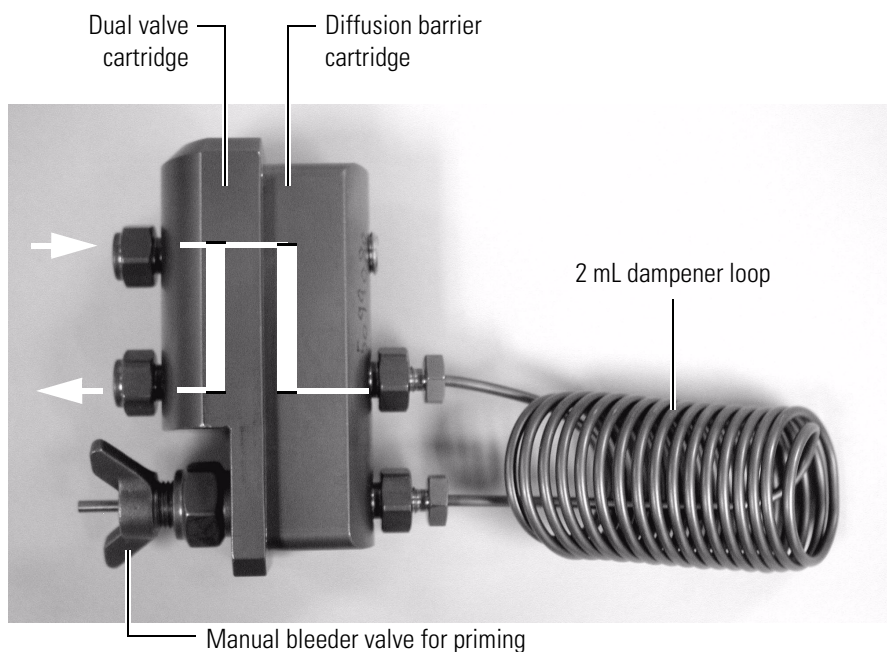

The loop is terminated with a priming valve. When the priming valve is open, the dampening loop can be flushed or filled with an appropriate solvent such as methanol or isopropanol. When the priming valve is closed, the diffusion barrier cartridge is shutoff from the flow path and the dampening loop absorbs pump pulsations. Even at elevated pressures, the pump shows only minimal pulsation when the pulse dampener is used. And because the 2 mL loop is shut off from the flow path, the low volume T-connector of the pulse dampener adds only 3 μL of delay volume to the system.

Because the membrane between the T-connector and the 2 mL loop is permeable, pumping buffered mobile phases leads to a slow buildup of electrolytes in the loop. To prevent corrosion in this situation, flush and prime the pulse dampener periodically.



CAUTION Do not open the manual bleeder valve during normal operation of the pump. If you open the valve while you are pumping an acidic or buffered mobile phase, prime the pulse dampener as soon as you notice the error. Because the pulse dampener is composed of two dissimilar metals, titanium and stainless steel, leaving acids or buffered solutions inside it causes galvanic corrosion and increased baseline noise.



CAUTION Do not confuse the manual bleeder valve with the venting valve on the left side of the LDA. The manual bleeder valve **is not** a purge valve for quickly drawing solvents through the solvent lines.

Status LEDs

Four status LEDs – labeled Power, Comm, Run, and Degas – are located on the right door of the pump. See [Figure 6](#). The states of these LEDs are described in [Table 1](#).

Figure 6. Front panel LEDs



Table 1. Status states for the Surveyor MS Pump Plus

LED	State	Meaning
Power	Amber	The MS Pump is switched On and is receiving power, but has not yet passed its Power On Self Test.
	Green	The MS Pump is switched On and is receiving power, and has passed its Power On Self Test.
Comm	Amber	The MS pump is not communicating with the data system PC
	Green	Communication to the data system PC has been established
	Flashing green	A pump program is downloading from the data system PC.
Run	Green	The MS pump is ready for a run.
	Flashing green	The MS pump is in a run.
Degas	Amber	The degas unit is building vacuum.
	Flashing amber	A failure, such as a loss of vacuum, has occurred.
	Green	Sufficient vacuum has developed to perform chromatography.

Specifications

The specifications for the Surveyor MS Pump Plus are listed below.

Minimum Flow Rate:	0.2 $\mu\text{L}/\text{min}$ isocratic, 25 $\mu\text{L}/\text{min}$ gradient
Maximum Flow Rate:	2000 $\mu\text{L}/\text{min}$
Flow Rate Resolution:	0.1 $\mu\text{L}/\text{min}$
Pressure Range:	0 to 400 bar (0 to 5800 psi)
Operating Range:	40 to 400 bar (588 to 5800 psi)
Pressure Resolution:	0.01 bar (0.15 psi)
Solvent Capacity:	Quaternary
Composition Accuracy:	$\pm 1\%$ at a flow rate of 200 $\mu\text{L}/\text{min}$
Piston Volume:	24 μL
Delay Volume:	80 μL
Degasser Type:	Vacuum membrane
Degasser Capacity:	4 channels
Degasser Volume:	< 500 μL per channel
Pulse Dampener:	3 μL , dynamic
Wetted Parts:	316 stainless steel, titanium, PEEK, sapphire, TZP-ceramic, FEP, GFP, ruby
Remote Controls:	Start, RS232 serial interface for Xcalibur software
Dimensions:	18 cm \times 36 cm \times 47 cm (<i>h</i> \times <i>w</i> \times <i>d</i>)
Weight:	12 kg
Power Requirements:	100/120 V ac or 220/240 V ac, 50 to 60 Hz, 500 VA max
Operating Temp:	+ 10 $^{\circ}\text{C}$ to + 40 $^{\circ}\text{C}$
Storage Temp:	- 40 $^{\circ}\text{C}$ to + 70 $^{\circ}\text{C}$
Operating Humidity:	5 to 95% relative, non-condensing

Installation

This chapter provides instructions for the initial installation of your Surveyor MS Pump Plus, including connection to other modules in the system. The Installation Checklist on the back of this page is an abbreviated version of the chapter and can be used as a quick reference of how to conduct a successful installation. Make a copy of the checklist and fill it out when the installation is complete. Include the completed checklist in your maintenance records.

Note Perform the installation in the sequence presented on the Installation Checklist and detailed in this chapter.

Contents

- [Installation Checklist](#)
- [Unpacking and Inspecting the Instrument](#)
- [Making the Initial Instrument Preparations](#)
- [Making the Initial Back Panel Connections](#)
- [Connecting the Low-Pressure Solvent Lines](#)
- [Connecting the Pump to the Surveyor Autosampler Plus](#)
- [Powering On for the First Time](#)
- [Preparing the Pump for Operation](#)

Installation Checklist

This topic provides a brief summary of the steps that must be completed for the proper installation of your Surveyor MS Pump Plus:

- Unpack and inspect your instrument (“[Unpacking and Inspecting the Instrument](#)” on [page 10](#)).
- Read the safety precautions.
- Position the pump appropriately (“[Making the Initial Instrument Preparations](#)” on [page 11](#)).
- Make the back panel connections (“[Making the Initial Back Panel Connections](#)” on [page 11](#)).
- Connect the solvent lines (“[Connecting the Low-Pressure Solvent Lines](#)” on [page 15](#)).
- Connect the power cord and turn on the instrument (“[Powering On for the First Time](#)” on [page 21](#)).
- Prime the pulse dampener (“[Priming the Pulse Dampener](#)” on [page 26](#)).

This Surveyor MS Pump Plus was installed by:

(Name)

(Date)

Unpacking and Inspecting the Instrument

Carefully remove the pump from the shipping container and inspect both the pump and packing for any signs of damage. If you find any damage, save the shipping materials and immediately contact the shipping company.

The shipping container should contain the pump, an accessory kit, a power cable, a serial communications cable with DB-9 pin connectors, and this manual. The accessory kit contains two 1/16 in. PEEK fittings, a 10 mL Luer-tipped syringe, a 4 mm balldriver with a screwdriver style handle, and a 4 mm Allen wrench.

Carefully check to make sure you received all the items listed on the packing list. If any items are missing, contact your Thermo Fisher Scientific service representative immediately.

Making the Initial Instrument Preparations

Place the pump on a laboratory bench as close as possible to a designated electrical outlet. Be sure to place the system in a **draft-free** location away from an open window, air conditioner vents, or other circulating air source. A stable room temperature is necessary for applications requiring maximum detection sensitivity. The area should also be free from dust, moisture, direct sunlight, strong electromagnetic fields, and physical vibrations. Allow at least 15 cm (6 in.) of clear space between the back panel of the pump and any wall or obstruction. This provides access to the back-panel connectors and a free flow of cooling air.



CAUTION Never connect the pump to, or operate the pump with, an electrical line source that has power drops or fluctuations of 10% below the nominal rated line voltage.



CAUTION Do not connect the power cord or turn on the pump yet. Wait until the [Powering On for the First Time](#) section of this chapter.

Making the Initial Back Panel Connections

In addition to connecting the MS pump to line power, operation of the Surveyor MS Pump Plus requires connecting two cables to the back panel of the pump. See [Figure 7](#). One is a serial communication cable that is used to download analytical methods to, and upload pressure information from, the pump. The other is a system synchronization cable that is used to coordinate the operation of the pump with the other Surveyor modules.

Figure 7. Back panel connections

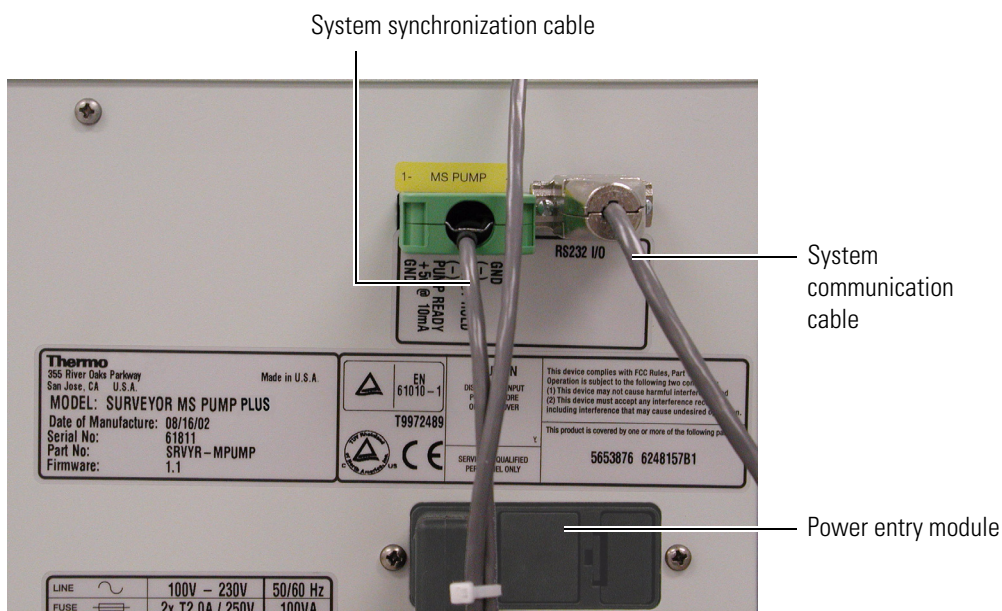

Serial Communication Cable

The serial communication cable is a standard RS232 cable, approximately 2 meters long and terminated at each end with a DB-9 pin connector. The serial communication cable is in the accessory kit.

❖ To install the serial communication cable

1. Connect one end of the serial communication cable to an available serial port on the host computer.
2. Connect the other end of the cable to the connector found on the back of the Surveyor MS Pump Plus (see [Figure 7](#)).

System Interconnect Cable

The interconnect cable coordinates the timing of the Surveyor Plus modules during an injection sequence.

The Surveyor Plus LC devices are shipped with two versions of the interconnect cable: a 5-connector version (F5049-010) and a 7-connector version (60053-63034).

This topic contains the following procedures:

- [Connecting the 5-Connector Interconnect Cable to the LC Devices](#)
- [Connecting the 7-Connector Interconnect Cable to the LC Devices](#)

Connecting the 5-Connector Interconnect Cable to the LC Devices

The 5-combicon connectors of the interconnect cable (P/N F5049-010) are labeled LC PUMP, MS PUMP, A/S, DET, and M/S. See [Figure 8](#).

Figure 8. 5-connector interconnect cable, P/N F5049-010

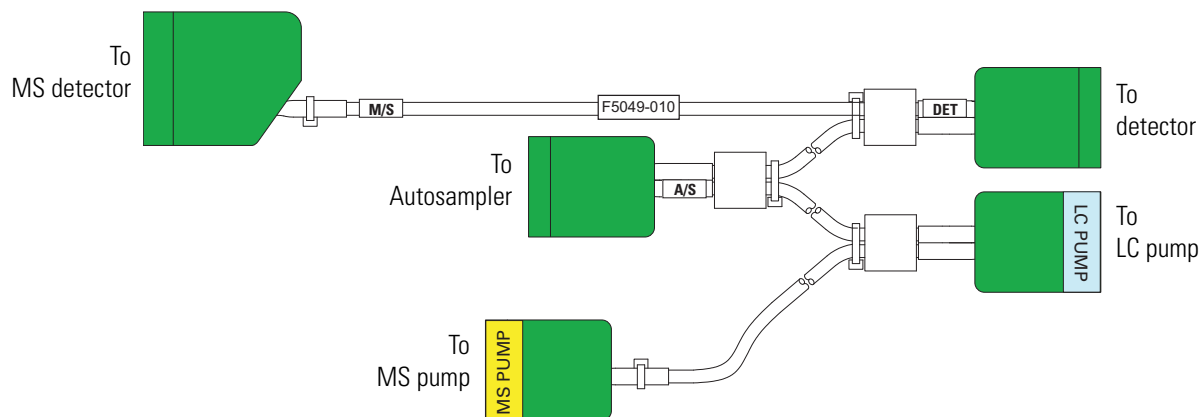

❖ **To connect the LC modules with the 5-connector interconnect cable**

1. To connect the autosampler, plug the A/S connector into the left, 8-pin socket on the back panel of the autosampler. See [Figure 9](#).
2. To connect the MS pump, plug the connector identified by the yellow MS PUMP sticker into the 8-pin receptacle on the back panel of the pump. There is a yellow MS PUMP label above the receptacle.
3. To connect a Surveyor PDA Plus Detector, plug the DET connector into the left, 8-pin socket on the back panel of the detector.
4. To connect a Surveyor FL Plus Detector, plug the DET connector into the adapter cable for the Surveyor FL Plus Detector. Then connect the other end of the adapter cable to the FL detector.

Figure 9. Back panels, showing the connections for the 5-connector interconnect cable

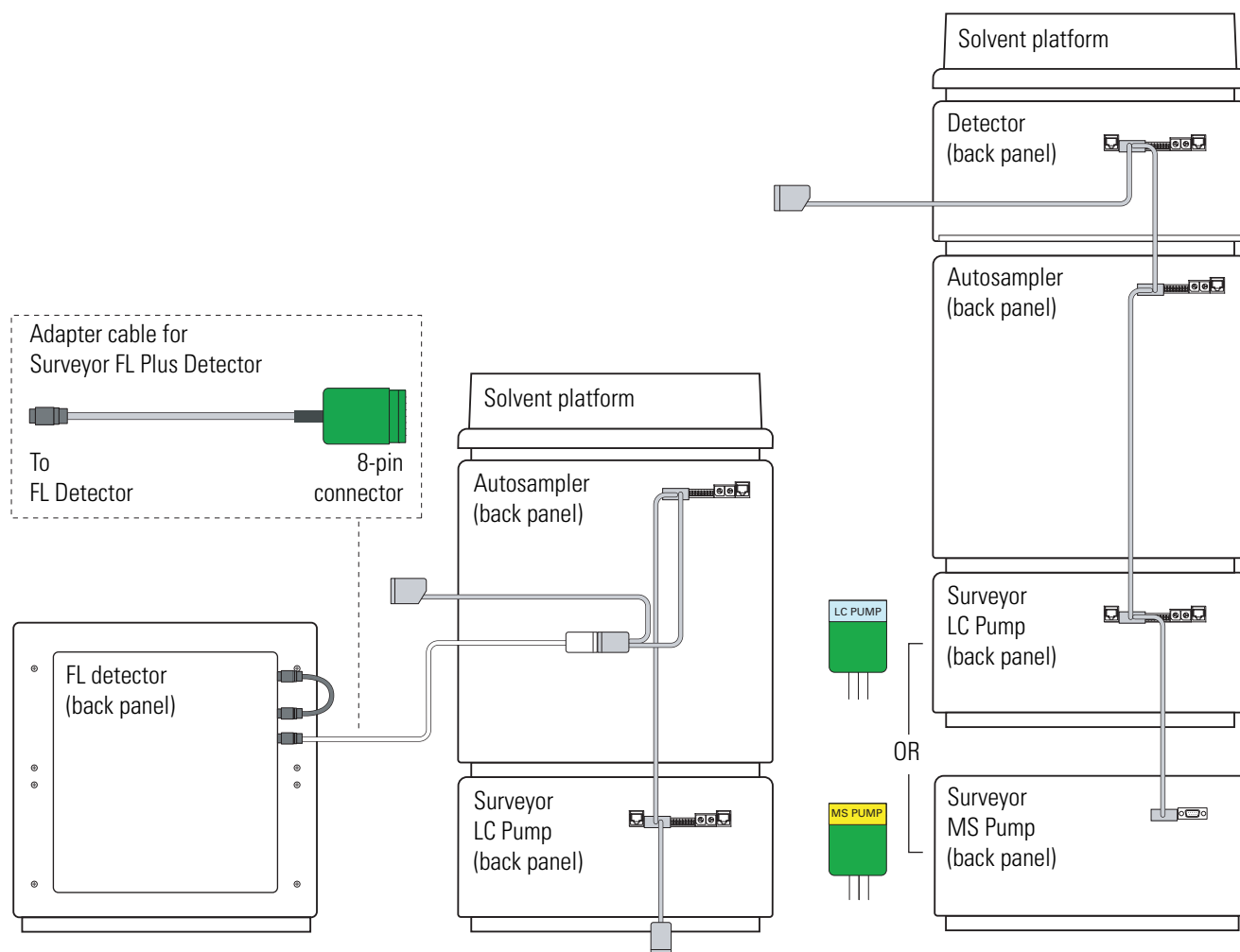

Not drawn to scale

Connecting the 7-Connector Interconnect Cable to the LC Devices

The 7-combicon connectors of the interconnect cable are labeled as follows: three connectors are labeled DETECTOR; two connectors are labeled PUMP; the connector for the A/S is identified by the A/S tag on its adjacent cable; the connector for the MS detector is identified by the M/S tag on its adjacent cable. See [Figure 10](#).

Figure 10. 7-connector version of the system interconnect cable

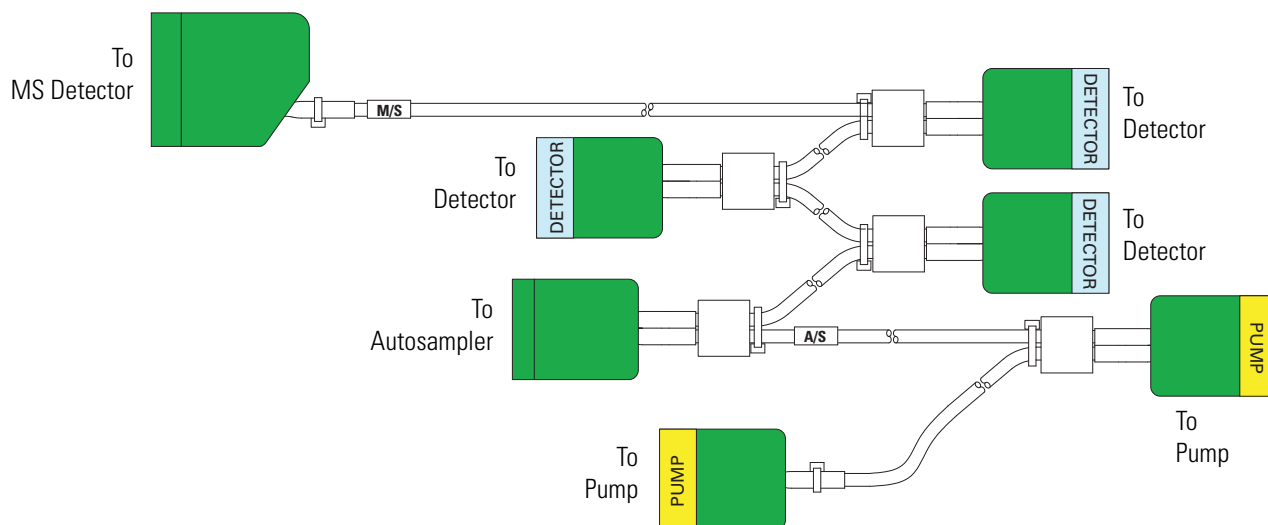

❖ To connect the LC modules with the 7-connector interconnect cable

1. To connect the Surveyor Autosampler Plus, plug the A/S connector into the left, 8-pin socket on the back panel of the autosampler.
2. To connect a Surveyor PDA Plus Detector, plug the detector connector into the left, 8-pin socket on the back panel of the detector.
3. To connect a Surveyor MS Pump Plus, do the following:
 - a. Connect the end of the adapter cable labeled PUMP to one of the pump connectors of the 7-connector interconnect cable. The adapter cable for the MS pump is shown in [Figure 11](#).
 - b. Plug the end of the adapter cable labeled MS PUMP into the 8-pin socket on the back panel of the MS pump. See [Figure 12](#).

Figure 11. Adapter cable for the Surveyor MS Pump Plus

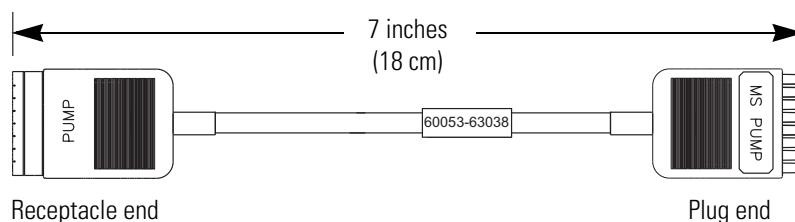
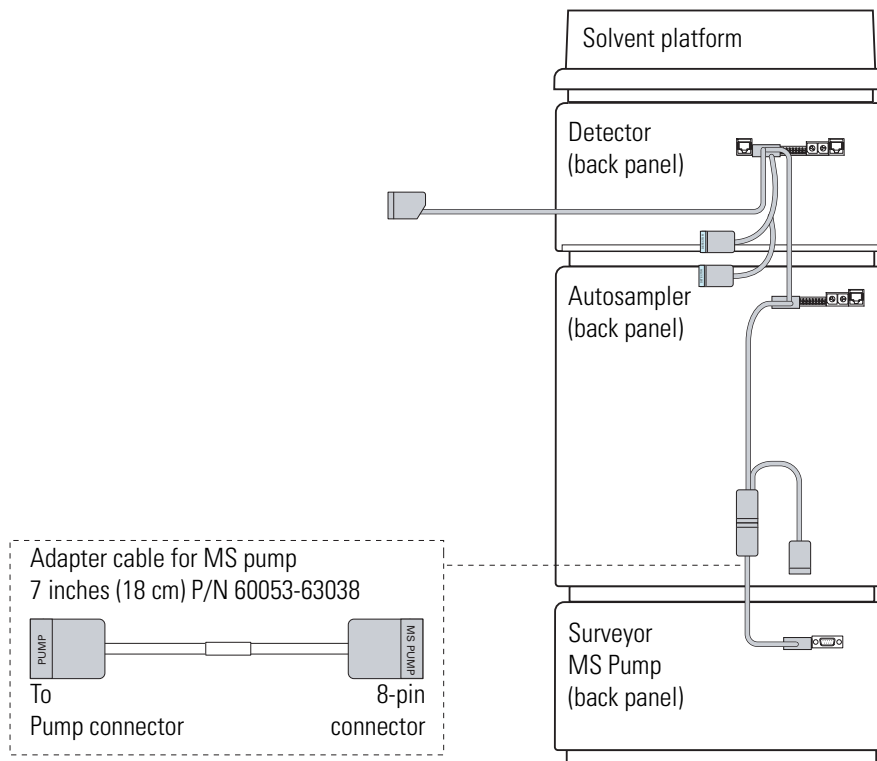

Figure 12. Back panels, showing the connections for the 7-connector interconnect cable

Connecting the Low-Pressure Solvent Lines

You need to connect the low-pressure solvent lines to the Surveyor MS Pump Plus before you operate the pump. There are four low-pressure lines that bring the four solvents to the pump.

Solvents should always be HPLC quality and free of particulate matter. Because the Surveyor MS Pump Plus contains very small, precision-machined parts, it can easily be affected by small particles entering the pump. Aqueous eluents are particularly susceptible to bacterial growth that can cause numerous problems.

To prevent bacteria and/or particulate matter from entering the pump, do the following:

- Filter all solvents thoroughly.
- Discard aqueous mobile phases on a daily basis or add a bactericide such as sodium azide to inhibit bacterial growth (0.65 g/l NaN_3 prevents growth of most kinds of bacteria).



CAUTION Sodium azide is highly toxic and carcinogenic. Take care when disposing of solutions that contain sodium azide because azides can react with heavy metals to form explosive compounds.

2 Installation

Connecting the Low-Pressure Solvent Lines

Air permeates through FEP tubing and can saturate solvents inside the solvent lines that connect the degassing assembly to the solvent proportioning assembly when the system is left static (for example, over a weekend). In this case, purging the lines for a few minutes proves effective.

The Surveyor System Accessory Kit (P/N SRVYR-SYSKT) contains 240 in. of 1/8 in. OD, 1/16 in. ID tubing to cut and use as the solvent inlet lines. Super Flangeless fittings are used to connect these lines to the inlet ports of the vacuum degas assembly of the Surveyor MS Pump Plus. The system accessory kit also contains solvent bottles, solvent bottle caps, and stick on labels for the bottle caps.

To install the solvent inlet lines, perform the following procedures:

- [Step 1: Assembling the Solvent Reservoir Bottles](#)
- [Step 2: Installing the Super Flangeless Fittings](#)

Step 1: Assembling the Solvent Reservoir Bottles

❖ To assemble the solvent reservoir bottles

1. Cut the 1/8 in. OD tubing into four sections of approximately 5-ft. each. Make sure that you cut the ends of the tubing squarely at a 90° angle.
2. Place the label A sticker onto one of the four solvent reservoir bottle caps.
3. Pass one end of the inlet line for solvent A through the solvent reservoir bottle cap labeled A. Terminate the inlet line with one of the solvent reservoir filters included in the system accessory kit. See [Figure 13](#).

Note A Teflon end-of-line filter is supplied with the system accessory kit for this pump. Use only non-metallic filters on the solvent lines.

Figure 13. Solvent reservoir cap assembly



4. Insert the solvent reservoir filter and inlet line into one of the solvent reservoir bottles, and screw the cap onto the solvent reservoir bottle until it is secure.

Note The cap is a two-piece assembly. The upper section (Figure 13) snaps onto a threaded section. The threaded section can be screwed onto the bottle and the upper section can be snapped on after the tubing has been installed, or, if you are replacing existing tubing, the entire cap can be unscrewed from the bottle.

5. Position the bottle in the Surveyor Solvent Platform, allowing the solvent inlet line to hang down along the left side of the Surveyor Plus system.

Step 2: Installing the Super Flangeless Fittings

The Super Flangeless™ fitting consists of three components: a nut, a ferrule, and a stainless steel compression ring (see Figure 14). The compression ring has two sides (see Figure 15). When you place the three components of the fitting on the end of a solvent line, the flattened side of the ring faces the nut and the angled side of the ring faces the ferrule.

Figure 14. Super Flangeless fitting components

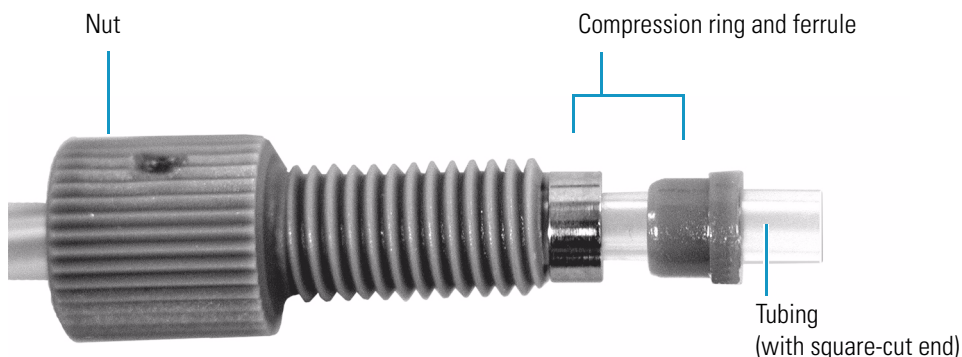
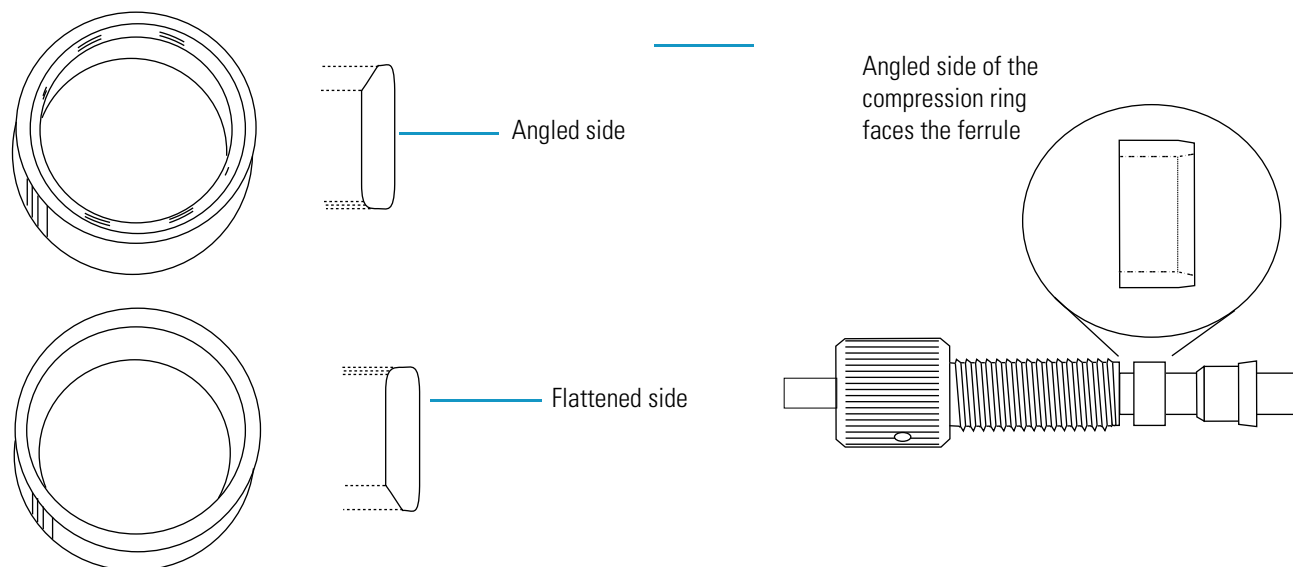

Figure 15. Drawing of the compression ring sides



2 Installation

Connecting the Low-Pressure Solvent Lines

❖ To install a Super Flangeless fitting

1. Slide the nut onto the end of the tubing.
2. With its flattened side facing toward the nut, slide the compression ring onto the end of the tubing.
3. With its narrow end facing the compression ring, slide the ferrule onto the end of the tubing.
4. Swage the fitting onto the tubing (see [Figure 16](#)):
 - a. Create a compression tool by screwing a Super Flangeless nut into one end of a 1/4 inch × 28 thread internal union.
 - b. Insert the tubing with the fitting assembly into the other end of the union.
 - c. Hold the tubing to the bottom of the tool while tightening down the nut.

Figure 16. Using a compression tool to swage the fitting onto the tubing

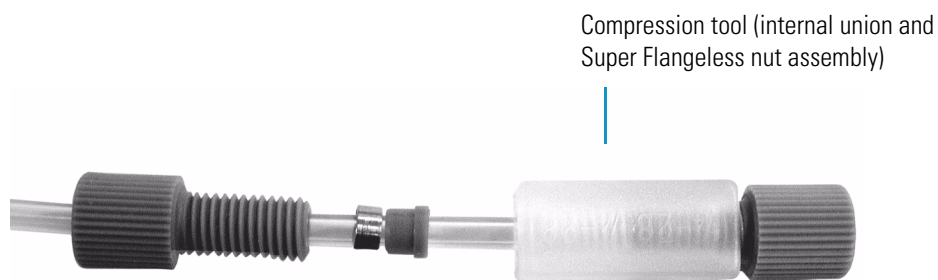

- d. Unscrew the swaged fitting and verify the following (see [Figure 17](#)):
 - The end of the square-cut tubing is flush with the end of the ferrule.
 - The steel compression ring is seated over the ferrule.

Figure 17. View of fitting swaged onto tubing

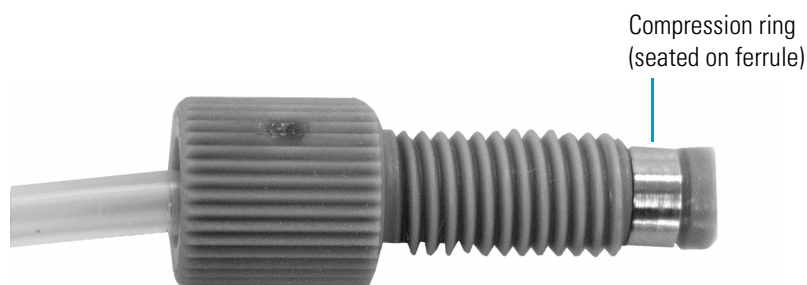

5. Insert the tubing with the properly swaged fitting into inlet port A, and then tighten the nut fingertight. Be careful not to cross-thread the fitting, which can cause solvent leakage (see [Figure 18](#)).
6. Pass the solvent inlet line through the openings along the left side of each Surveyor Plus module to complete the installation.
7. Repeat the above steps for the B, C, and D solvent inlet lines.

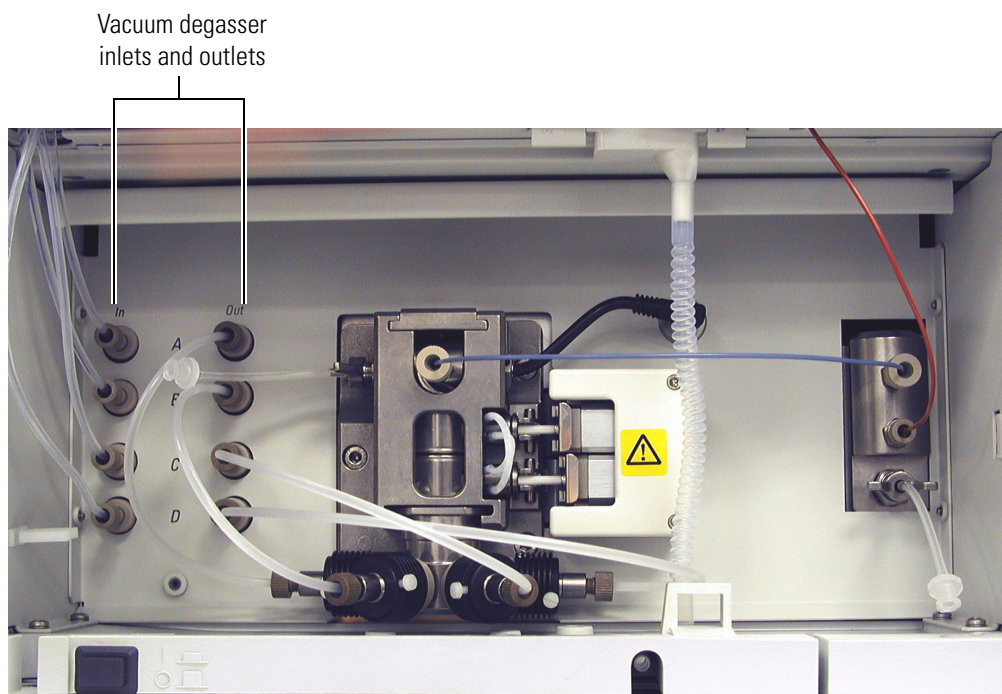
Figure 18. Vacuum degas connection

Connecting the Pump to the Surveyor Autosampler Plus

The solvent outlet tubing is a 1/16 in. stainless steel tube that is used to deliver mobile phase from the Surveyor MS Pump Plus to the Surveyor Autosampler Plus. The tubing, which is pre-installed on the autosampler inlet, has an internal diameter of 0.020 in. A 1/16 in. stainless steel nut and PEEK ferrule, Fingertight fitting is included to connect the tubing to the outlet fitting of the pulse dampener of the MS pump.

❖ To connect the MS pump to the inlet tubing of the autosampler

1. Place the Surveyor Autosampler Plus on top of the Surveyor MS Pump Plus. Locate the autosampler inlet tubing (extending out of the column oven) to be connected to the pump.
2. Carefully bend the Surveyor Autosampler Plus inlet tubing so that it passes through the access port found on the bottom-right side of the Surveyor Autosampler chassis.
3. Connect the tubing to the outlet of the pulse dampener using the 1/16 in. stainless steel nut and PEEK ferrule (P/N 00101-18088) included in the Surveyor MS Pump Plus accessory kit. Be careful not to over-tighten the fitting.

2 Installation

Connecting the Pump to the Surveyor Autosampler Plus

Note To decrease the gradient delay volume of your system, bypass the tubing behind the column oven. This tubing allows the mobile phase to equilibrate to the requested column oven temperature, but it also adds 250 μL of gradient delay volume. To bypass this tubing, disconnect it from port 5 of the injection valve, and then connect the pulse dampener outlet directly to this port.

❖ To connect the pump directly to the autosampler's injection valve

1. Place the Surveyor Autosampler Plus on top of the Surveyor MS Pump Plus.
2. Disconnect the stainless steel tubing from port 5 of the Autosampler's injection valve.
3. Use 0.005 in. ID PEEK tubing or the 30 cm (12 in.) l, 0.010 in. ID, stainless steel tubing (P/N A0941-010) provided in the autosampler accessory kit, a Valco injection valve fitting, and the 1/16 in. stainless steel nut and PEEK ferrule (P/N 00101-18088) included in the Surveyor MS Pump Plus accessory kit to connect the outlet of the pulse dampener directly to port 5 of the injection valve. See [Figure 19](#).

The Surveyor MS Pump Plus is now properly connected.

Figure 19. Solvent outlet tubing connection to autosampler

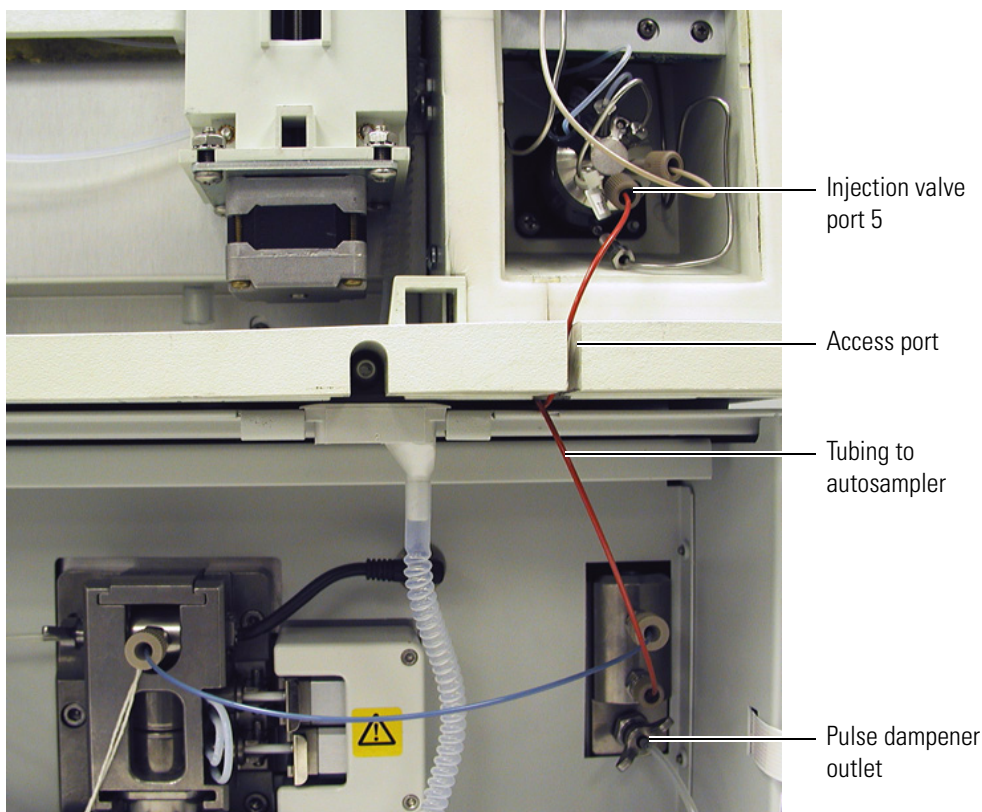

Powering On for the First Time

After the solvent lines and tubing are installed, the pump is ready to be powered on.

❖ To turn on the pump

1. Ensure that the power switch at the front of the unit is in the Off position (released or Out-position).
2. Attach the power cord to the power entry module on the back panel of the pump and connect to the power source (Figure 7).
3. Push the power On button to engage it (In-position).
4. Note that the power indicator turns solid green (see Figure 6 on page 6). If it does turn green, see “Surveyor MS Pump Troubleshooting Guide” on page 70. Call your Thermo Fisher Scientific service representative if you require assistance.

Configuring the Data System PC COM Port

Communication with the Surveyor MS Pump is established through an RS232 connection.

❖ To configure the COM port:



1. From the Windows taskbar, choose **Start > Control Panel**.
2. Double-click the **System** icon to open the System Properties dialog box.
3. Click the **Hardware** tab, and then click **Device Manager**.
4. Double-click **Ports (COM & LPT)**. The available ports are displayed below Ports (COM & LPT) in the Device Manager list.
5. Double-click **Communication Port (COM1)** to display the Communication Port (COM1) Properties dialog box.
6. Click the **Port Setting** tab.
7. Set the configuration parameters
 - Bits per Second: 19200
 - Data Bits: 8
 - Parity: none
 - Stop Bits: 1
 - Flow Control: none
8. Click **OK** to save the changes and close the Communication Port (COM1) Properties dialog box.

9. Close the Device Manager window.
10. Click **OK** to close the System Properties dialog box.
11. Restart the computer to enable the new settings.

Preparing the Pump for Operation

After you connect the solvent lines to their respective degas inlets, you are ready to prepare the pump for operation. To prepare the pump for operation, first configure the MS pump to communicate with the Xcalibur data system. Then purge the air out of the solvent lines, and prime the pulse dampener.

This section contains the following topics:

- [Specifying the Instrument Configuration Options](#)
- [Purging Air from the Solvent Lines](#)
- [Priming the Pulse Dampener](#)

Specifying the Instrument Configuration Options

You can use the Surveyor MS Pump Plus (or Surveyor MS Pump) with the Surveyor Autosampler Plus or the CTC PAL autosampler (Thermo PAL driver). You can also set up a system consisting of two Surveyor pumps.

This topic describes the Xcalibur instrument configuration options for the Surveyor MS Pump Plus as well as the configuration options for the Surveyor Autosampler Plus that are required to ensure that the autosampler recognizes the output signals from the pump.

Note The user interface for the Instrument Configuration application compatible with Xcalibur 2.1 or higher has a slightly different appearance than the Instrument Configuration application compatible with earlier Xcalibur versions.

To specify the instrument configuration options, follow these procedures:

- [Opening the Instrument Configuration Application](#)
- [Adding the Surveyor MS Pump or Surveyor MS Pump Plus to the Instrument Configuration](#)
- [Configuring the Signal Polarity for the Surveyor AS](#)

Opening the Instrument Configuration Application

Use the Instrument Configuration (Thermo Foundation Instrument Configuration) window to specify the system hardware components.

❖ To open the Instrument Configuration window for systems using Xcalibur 2.1

From the Windows taskbar, choose **Start > All Programs > Thermo Foundation > Instrument Configuration**.

The Thermo Foundation Instrument Configuration window appears.

❖ To open the Instrument Configuration window for systems using Xcalibur 2.0.x or lower

- From the Windows taskbar, choose **Start > All Programs > Xcalibur > Instrument Configuration**.
- Or, double-click the Xcalibur Instrument Configuration icon on the Windows desktop.

The Instrument Configuration window appears.

Adding the Surveyor MS Pump or Surveyor MS Pump Plus to the Instrument Configuration

❖ To add the pump to the Instrument configuration

1. Open the Instrument Configuration window.
2. In the Available Devices list, double-click the icon for the pump.

A copy of the icon appears in the Configured Devices list.

3. In the Configured Devices list, double-click the pump icon.

The Surveyor MS Pump Plus (or Surveyor MS Pump) dialog box appears.

Configuring the Signal Polarity for the Surveyor AS

During an injection sequence, the Surveyor MS Pump Plus issues a Pump Ready signal and an Injection Hold Release signal to the autosampler.

When you configure the Surveyor Autosampler Plus, select the Pump ready active high check box and the Injection hold release active high check box. If you do not select these two check boxes, the autosampler cannot recognize the input signals from the pump and does not begin an injection sequence.

After you submit a run, the Surveyor Autosampler Plus waits for a Pump Ready signal from the pump. The pump issues this signal after its pressure transducer monitors a stable backpressure. When the autosampler receives this signal, it begins an injection sequence.

After the autosampler begins the injection sequence, it waits for an Injection Hold Release signal from the pump. The pump issues this release signal when its piston cam returns to the start position. When the autosampler receives the Injection Hold Release signal, it switches the injection valve to the inject position, allowing the contents of the sample loop to be swept into the mobile phase stream from the pump.

Note In Xcalibur, the instrument setup method for the pump contains a custom stability limit parameter. This parameter allows the user to define the acceptable level of pressure stability that must be attained before the pump issues the Pump Ready Signal to the autosampler.

❖ To configure the input signal polarities for the Surveyor Autosampler

1. If it is not already open, open the Instrument Configuration window (see “Opening the Instrument Configuration Application” on page 23).

2. In the Configured Devices list, double-click the **Surveyor AS** icon.

The Surveyor Autosampler dialog box appears.

3. Click the **Signal polarity** tab.

The Signal polarity page appears (see Figure 20).

Figure 20. Surveyor Autosampler Configuration dialog box

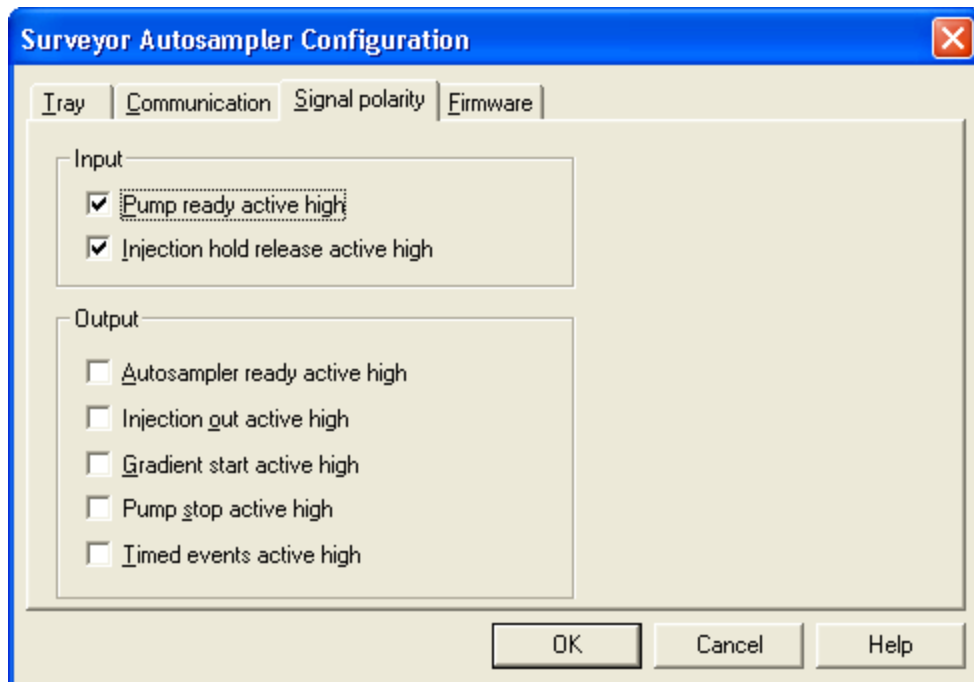

4. In the Input area, make sure that the **Pump ready active high** and **Injection hold release active high** check boxes are selected.

Purging Air from the Solvent Lines

After you fill the solvent bottles, connect the solvent lines to the degasser, and configure the MS pump to communicate with Xcalibur, prepare the pump for operation by removing the air from the solvent lines.

❖ To remove air from the solvent lines

1. Insert the tip of the 10 mL syringe into the tubing that is connected to the wingnut on the left side of the LDA. See [Figure 21](#).
2. Open the wingnut by turning it counterclockwise.

Figure 21. Purging the solvent lines

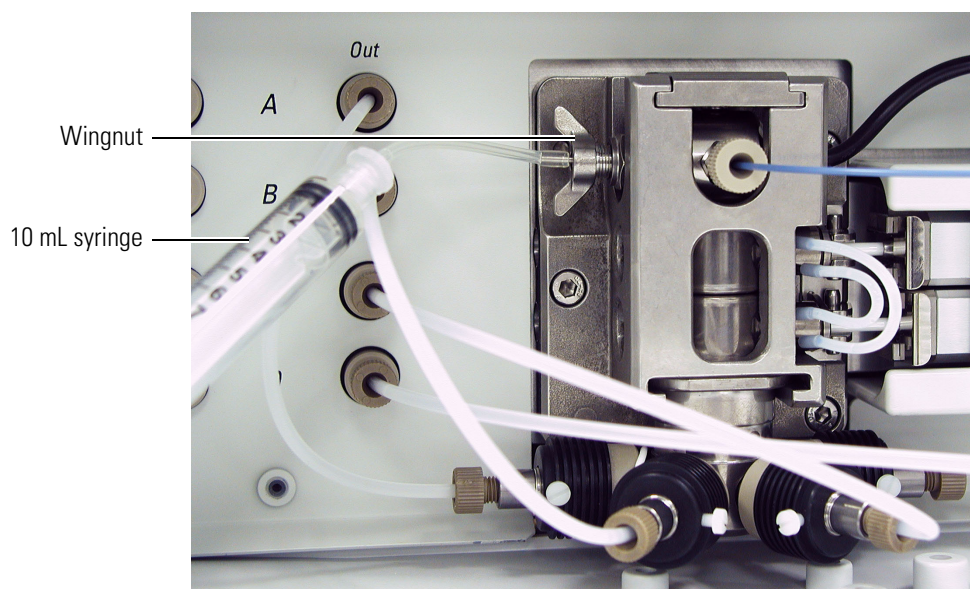

3. Turn on the pump power.
4. Open the Direct Control dialog box for the pump:
 - a. Open Xcalibur.
 - b. On the Roadmap view, click the **Instrument Setup** button. Or, from the menu bar, choose **GoTo > Instrument Setup**.
 - c. In the view bar, click the **Surveyor MS Pump Plus** (or **Surveyor MS Pump**) button.
 - d. Choose **Surveyor MS Pump Plus** (or **Surveyor MS Pump**) > **Direct Control** from the Instrument Setup window to open the Direct Control dialog box.
5. In the Direct Control dialog box (see [Figure 22](#)), do the following:
 - a. Select the **Take pump under control** check box.
 - b. Type percentages in the Inlet boxes for the solvent lines through which you want to draw solvent.



2 Installation

Preparing the Pump for Operation

- c. In the Flow box, type **2000**.
- d. Click the **Start Run** button  to start the pump flow.

Because each 1.5 m (5-ft.) section of tubing holds approximately 3 mL of solvent, you need to stop the pump flow and empty the syringe periodically.

Figure 22. Direct Control dialog box for the pump

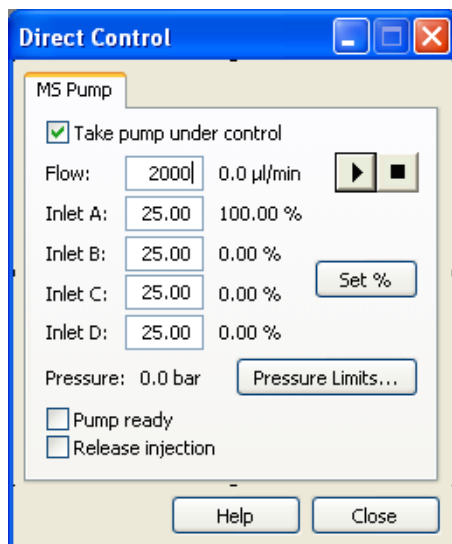

6. After you finish purging the solvent lines, click the **Stop** button  to stop the pump flow.
7. Turn the LDA wingnut clockwise to close the venting valve.

Priming the Pulse Dampener

Priming the pulse dampener involves filling the dampening loop of the pulse dampener with a solvent such as methanol or isopropanol. After the loop is filled with solvent, it can effectively dampen pressure pulsations from the rest of your system. Closing the manual bleeder valve after you fill the loop shuts the loop off from the flow path. For standard operation, reprime the pump when you notice an increase in the pump pulsation. If you accidentally open the manual bleeder valve on the front of the pulse dampener while you are pumping an acidic or a buffered mobile phase, immediately flush the buffer out of the loop, and then prime the pulse dampener. See [Figure 23](#).

Figure 23. Pulse dampener assembly

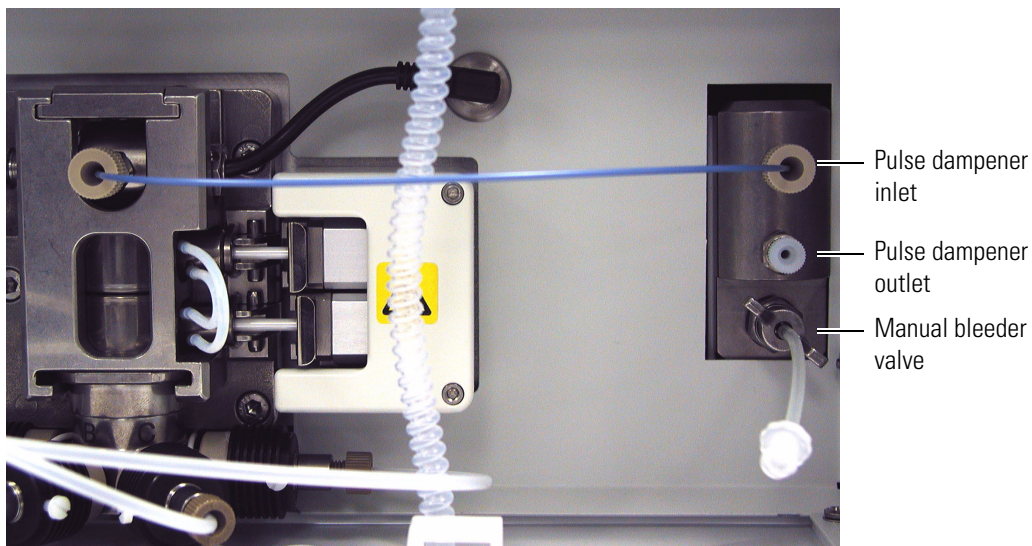

Note Do not fill the pulse dampener with an aggressive acid or a buffered solution. The recommended filling solvents are methanol, acetonitrile, or isopropyl alcohol. If you accidentally fill the pulse dampener with an acidic or buffered solvent, flush the loop with a miscible solvent, and then refill it with methanol, acetonitrile, or isopropyl alcohol.

❖ **To prime the pulse dampener**

1. Fill a solvent reservoir with particulate-free, HPLC grade methanol.
2. Connect an HPLC column or a flow restrictor to the pulse dampener outlet.
3. Insert the tip of the 10 mL syringe into the tubing that is connected to the manual bleeder valve of the pulse dampener, and then open the valve by turning it counterclockwise.
4. Set the flow rate to 1 mL/min.
5. Fill the loop completely, to expel any air that might be trapped in the dampener loop.
6. Set the pump flow to a rate that is appropriate for your system.
7. Close the manual bleeder valve of the pulse dampener by turning the valve clockwise.

The pulse dampener loop is now filled. Unless you need to refill the dampener loop of the pulse dampener with fresh solvent, keep the manual bleeder valve closed.

Diagnostics

This chapter contains the following diagnostic procedures that can be performed on the Surveyor MS Pump Plus.

Contents

- [Monitoring Pump Pulsation](#)
- [Testing the Pump Proportioning](#)
- [Determining the Delay Volume of the Pump](#)

Monitoring Pump Pulsation

The pump pulsation should be less than 1% at backpressures greater than 100 bar (1450 psi).

Note The Surveyor MS Pump Plus pressure fluctuation often appears to be higher than that for conventional pumps, because the Surveyor MS Pump Plus does not use electronic pulse damping.

The pressure pulsation can be directly monitored through the Xcalibur data system. You can find the pressure information in the Status page of the Information view as shown in [Figure 24](#). This view is normally displayed on the left side of the Home Page window.

If the Info view is not displayed, it has been turned off. From the Home Page window, choose **View > Info View** to toggle the Information view On and Off. Then, click the Status tab to display the Status page.

Figure 24. Status page of the Information view

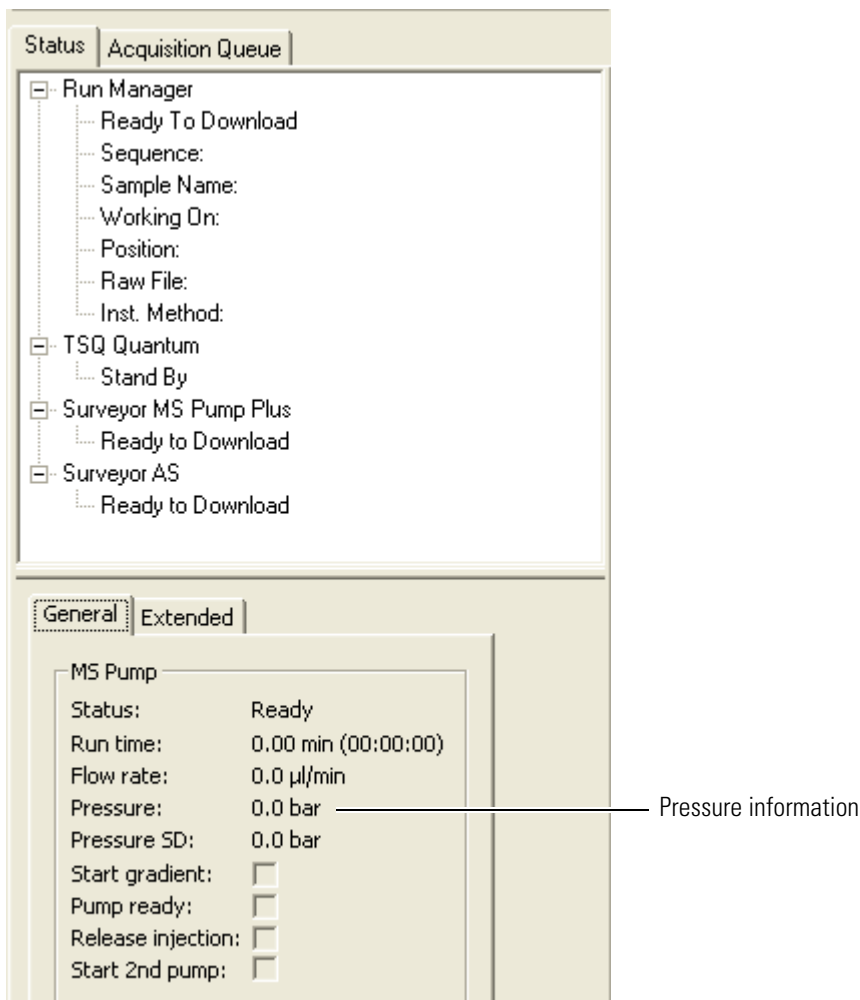

Trapped air bubbles, contaminated proportioning valves, or contaminated check valves can cause excessive pump pulsation. If the pulsation of the pump is greater than 1% at pressures greater than 100 bar, purge air out of the piston chambers as described on [page 31](#), and clean the proportioning valves and the check valves as described in “[Cleaning the LDA Components without Disassembling the LDA](#)” on [page 38](#).

If you cannot reduce the variation in backpressure by performing these procedures, disassemble and clean the LDA and replace the primary piston seals as described in “[Replacing the Primary Piston Seals](#)” on [page 49](#).

Testing the Pump Proportioning

You need to test the proportioning accuracy of the pump periodically by running a step-gradient.

Two eluents, methanol and spiked methanol, are used in this procedure. The absorbance reading for the 100% spiked methanol solution should be in the 600 to 800 mAU range.

- If your detector contains a standard 10 mm flow cell, prepare the spiked methanol solution by adding 7 mg of ethyl paraben (P/N A4904-010) to 1 L of HPLC grade methanol.
- If your detector contains a 50 mm LightPipe flow cell, prepare the spiked methanol solution by adding 1.4 mg of ethyl paraben to 1 L of HPLC grade methanol.

The step gradient program is shown in [Table 2](#). Use the following conditions to run the step gradient:

- Flow: 200 μ L/min
- Pressure: approximately 100 bar by restriction
- Eluents: A: methanol
- B: spiked methanol
- Sub-proportioning: Off
- Steps: 10 min hold, 20% increments
- Detection: UV (254 nm)

Table 2. Gradient Program

Time (min)	%A	%B
0.00	100.0	0.0
10.0	100.0	0.0
10.01	80.0	20.0
20.0	80.0	20.0
20.01	60.0	40.0
30.0	60.0	40.0
30.01	40.0	60.0
40.0	40.0	60.0
40.01	20.0	80.0
50.0	20.0	80.0

3 Diagnostics

Testing the Pump Proportioning

Table 2. Gradient Program

Time (min)	%A	%B
50.01	0.0	100.0
60.0	0.0	100.0

Plumb your system to bypass the autosampler. Use the tubing supplied with the Surveyor system (P/N 803260, Inlet tubing, with insulation, PEEK 1/16 in. OD × .005 in. ID, Red) to connect the pump directly to the detector. Use a flow restrictor to maintain a backpressure greater than 40 bar.

The resulting gradient profile should contain five steps of equal height. See [Figure 25](#). Inaccuracies in the step heights indicate proportioning errors.

Figure 25. Step gradient profile for testing compositional accuracy

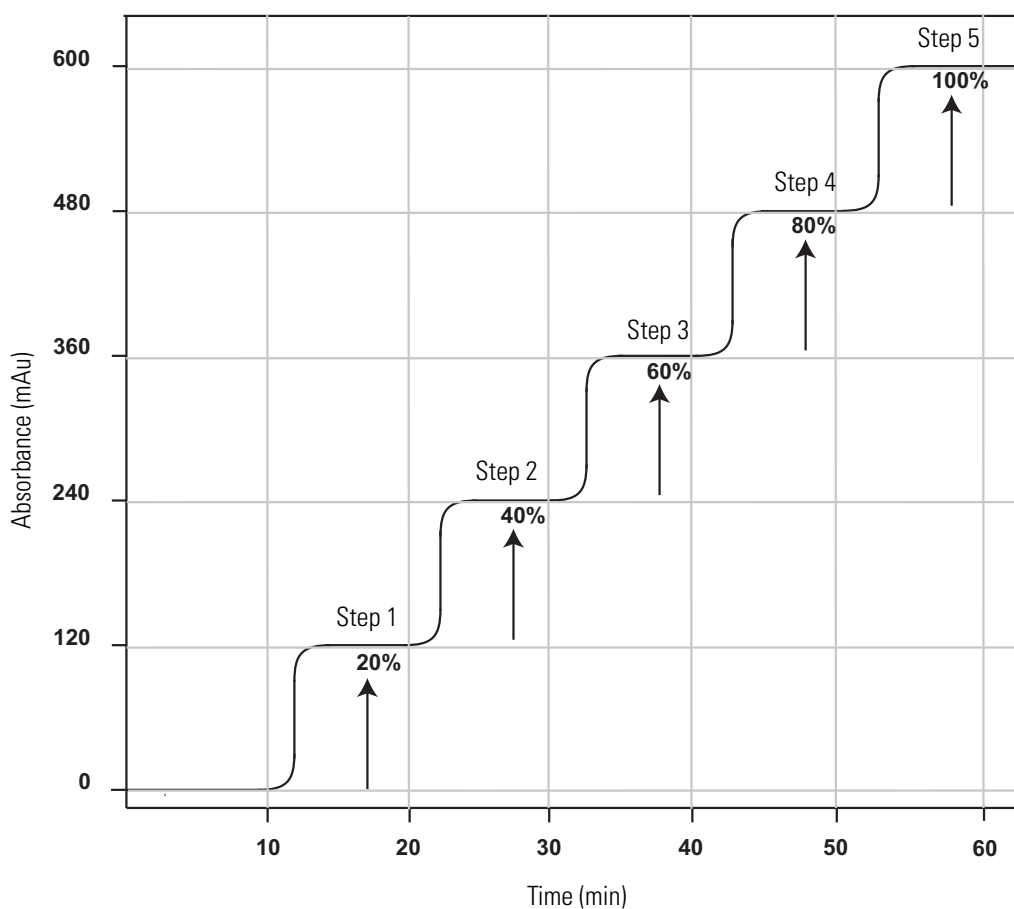

Step heights should be within $\pm 1\%$ of the theoretical values. In the step gradient shown in [Figure 25](#), the absorbance value for 100% spiked solvent is 600 mAU (600 mAU – 0 mAU). Therefore, the theoretical values for the 20%, 40%, 60%, and 80% steps are 120, 240, 360, and 480 mAU, respectively. A deviation greater than 6 mAU for any of the steps would be a failing result. If the pump passes both the pulsation and proportioning tests, it is working properly.

If the pump fails the pulsation test or the proportioning test, try to restore proper performance by cleaning the proportioning valves as described in [“Cleaning the LDA Components without Disassembling the LDA”](#) on [page 38](#). If this fails to restore proper pump performance, disassemble and clean the LDA and replace the primary seals as described in [“Replacing the Primary Piston Seals”](#) on [page 49](#).

Determining the Delay Volume of the Pump

The gradient delay volume of your pump is an important variable if you are developing gradient methods for use on multiple LC systems.

The gradient delay volume of your Surveyor MS Pump Plus consists of the wetted components that lie in the flow path between the solvent proportioning valves of the pump and the outlet of the pulse dampener.

Note The tubing located behind the built-in column oven of the Surveyor Autosampler contains approximately 250 μL of gradient delay volume.

❖ To determine the gradient delay volume of your MS pump

1. Set up your system:
 - a. Bypass the autosampler by connecting the pump directly to the detector with tubing of known volume. Each inch of the inlet tubing to the Surveyor PDA detector (P/N 803260, Inlet tubing, with insulation, PEEK, 1/16 in. OD \times 0.005 in. ID, Red) contains 0.32 μL of gradient delay volume.
 - b. Prepare a spiked methanol solution as specified in [“Testing the Pump Proportioning”](#) on [page 31](#).
 - c. Fill one solvent reservoir bottle with 100% methanol.
 - d. Fill one solvent reservoir bottle with the spiked methanol solution.
 - e. Purge the solvent lines until the old solvents are replaced with the new solvents.
2. Create an instrument method:
 - a. In the General page of the Surveyor MS Pump Plus Instrument Setup view, type the solvent names.
 - b. In the Gradient page of the Surveyor MS Pump Plus Instrument Setup view, add a time line for 0.01 minutes. Switch the mobile phase solvent to the spiked methanol

3 Diagnostics

Determining the Delay Volume of the Pump

- solvent at this time point. Enter a flow rate of 200 $\mu\text{L}/\text{min}$ for both the 0.00 min time line and the 0.01 min time line.
- Program your detector to collect one channel at 254 nm for a period of 5 minutes.
 - Save the method.
- Equilibrate the system until the baseline stabilizes:
 - In the Direct Control dialog box, take the pump under control, and set the parameters to 100% methanol and a 200 $\mu\text{L}/\text{min}$ flow rate.
 - Click the Start button .
 - Create a one-line sequence containing the acquisition method.
 - Run the sequence.
 - Calculate the gradient delay volume of the pump:
 - Determine the total gradient delay volume by multiplying the resulting gradient delay time by the flow rate.
 - Determine the gradient delay volume of the pump by subtracting the volume of the tubing connecting the pump to the detector from the total gradient delay volume.

The results of your run should look like the chromatogram shown in [Figure 26](#). If the start of the baseline shift occurs at 0.45 minutes, then the gradient delay volume of the pump is calculated as follows:

$$\begin{aligned}\text{Gradient Delay Volume of Pump} &= (T1 \times \text{Flow Rate}) - \text{tubing volume} \\ &= (0.45 \text{ min} \times 200 \text{ } \mu\text{L}/\text{min}) - 8 \text{ } \mu\text{L} \\ &= 82 \text{ } \mu\text{L}\end{aligned}$$

Figure 26. Graphical display of the baseline shift that occurs as the spiked mobile phase reaches the detector

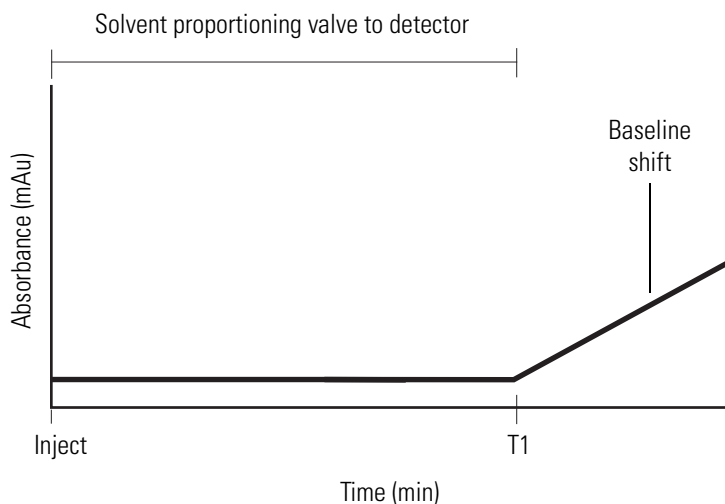

Maintenance

To properly maintain your pump, monitor its performance. Routinely examine the pump for leaks, and monitor the variation in pump pulsation. In addition, periodically test the proportioning accuracy of the pump. To lengthen the lifespan of the seals, always flush the piston guide bushings with distilled water after pumping buffered solutions.

If the pump pulsation is too high, try removing air from the LDA and cleaning the LDA components. If you detect a leak, disassemble the LDA, clean its components, and replace the primary piston seals.

Contents

- [Flushing the Piston Guide Bushings](#)
- [Purging Air from the Piston Chambers](#)
- [Cleaning the LDA Components without Disassembling the LDA](#)
- [Servicing the LDA](#)
 - [Removing the LDA from the Pump](#)
 - [Disassembling the LDA](#)
 - [Cleaning the LDA Components](#)
 - [Replacing the Primary Piston Seals](#)
 - [Reassembling the LDA](#)
 - [Reinstalling the LDA](#)
- [Servicing the Proportioning Valves](#)
- [Replacing the Solvent Reservoir Filter](#)

Flushing the Piston Guide Bushings

As the pistons move back and forth within the piston chambers, a small quantity of mobile phase leaks behind the primary piston seals. With buffered mobile phases, a precipitate (also known as creep or salt build-up) forms as the liquid fraction evaporates. The abrasion caused by this precipitate can scratch the piston and shorten the life of the piston seals.

To lengthen the lifespan of the primary piston seals and the pistons, always rinse the piston guide bushings with distilled water after pumping buffered solutions. See [Figure 27](#).

The piston guide bushings are supplied with two pieces of standard 1/8 in. × 1/16 in. PTFE tubing.

❖ To flush the piston guide bushings

1. If the outer piece of PTFE tubing has not been cut, cut it through the middle.
2. Connect a syringe filled with distilled water to the bottom piece of outer tubing and gently flush the water through the system.

Figure 27. Flushing the piston guide bushings

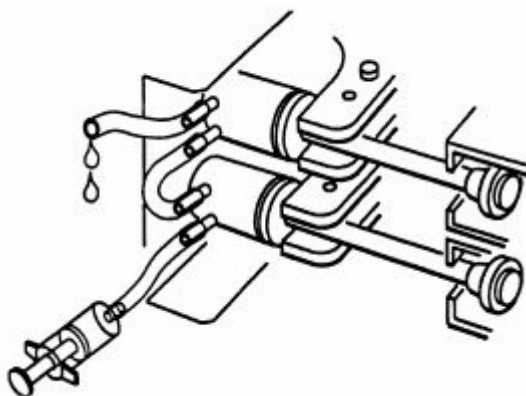

Purging Air from the Piston Chambers

Air trapped in the piston chambers causes an excessive variation in the backpressure.

❖ To purge air out of the piston chambers

1. Open the venting valve by turning the wingnut on the left side of the LDA counterclockwise. See [Figure 28](#).

Figure 28. Purging air from the piston chambers

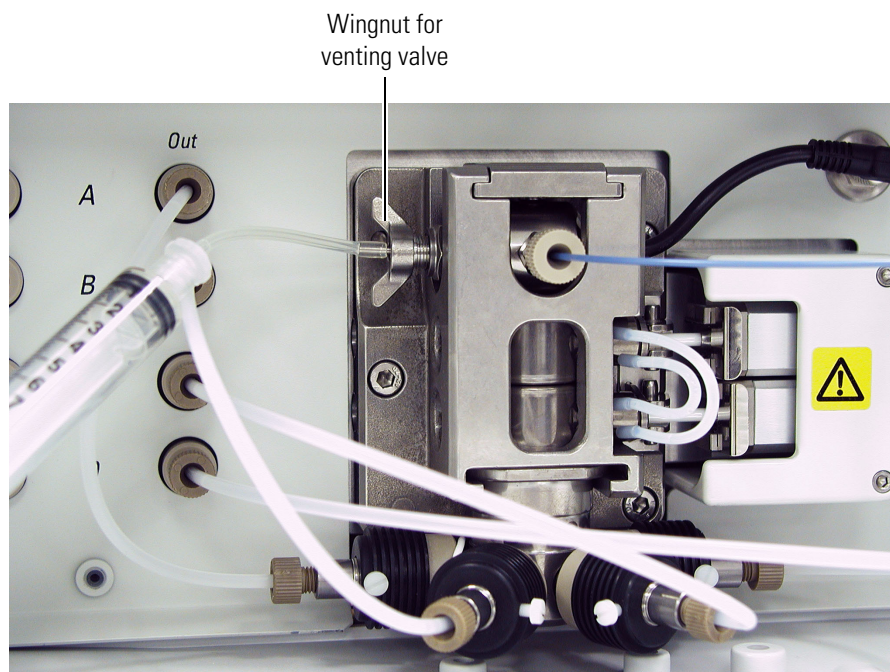

2. Insert the 10 mL syringe, which is supplied in the accessory kit, into the tubing attached to the venting valve, and then pump 100% methanol or 100% acetonitrile through the LDA at a flow rate of 200 $\mu\text{L}/\text{min}$ for a period of 10 to 15 min.
3. Close the venting valve and return to your initial conditions.
4. Check the pressure variation to determine if performing this procedure remedied the pressure stability problem.

Note Purging the pump at a low flow rate with 100% organic solvent works much better than purging the pump at a high flow rate with (partly) aqueous eluents.

Note All HPLC pumps require proper eluent degassing. The Surveyor MS Pump Plus has a built-in vacuum degasser. Plumbing the pump to bypass this degasser introduces a potentially unacceptable level of air into the piston chambers.

Cleaning the LDA Components without Disassembling the LDA

Contaminated check valves and contaminated proportioning valves can cause an excessive variation in backpressure. To remove the contamination, open the venting valve to bypass the LC column and pump the appropriate flush solvents through the LDA.

❖ To clean the check valves and the proportioning valves

1. Open the venting valve by turning the wingnut on the left side of the LDA counterclockwise (see [Figure 28](#)).

Note Opening the venting valve redirects the mobile phase out the venting valve on the left side of the LDA rather than into the crossover tubing. If you forget to open the venting valve, the flush solvents pass through the pulse dampener and onto your LC column.

2. Set up the system to pump the same solvent on all four channels by connecting all four solvent reservoir lines to one solvent bottle.
3. Attach a 10 mL disposable syringe to the tubing attached to the vent valve. The syringe is supplied in the MS Pump Accessory Kit (see “[MS Pump Accessory Kit](#)” on [page 80](#)).
4. If you were pumping buffered mobile phase through the system, pump HPLC-grade water on all four channels at a flow rate of 200 $\mu\text{L}/\text{min}$ for 30 minutes. Empty the contents of the syringe into a suitable waste receptacle, and then pump an additional 6 mL of water through the LDA.
5. Sequentially pump solvents of increasing polarity through the LDA. The last flush solvent should be miscible with the mobile phase that you plan to use.

Table 3. Polarity indexes of various HPLC solvents

Solvent	Polarity index
Isopropanol	3.9
Methanol	5.1
Acetonitrile	5.8
Water	9.0

6. Close the vent valve.
7. Retest the pressure variation by returning to the initial conditions that displayed the problem. Make sure that the backpressure at these conditions is at least 40 bar.

Servicing the LDA

The liquid displacement assembly (LDA) contains the parts of the pump that are subject to routine wear and tear. These parts are the primary piston seals, the pistons, and the check valves. Occasionally, the secondary piston seals, the check valve seal rings in the top and bottom of the piston chambers, and the outlet seal ring might also require replacement.

Figure 29. Components of the liquid displacement assembly (LDA)

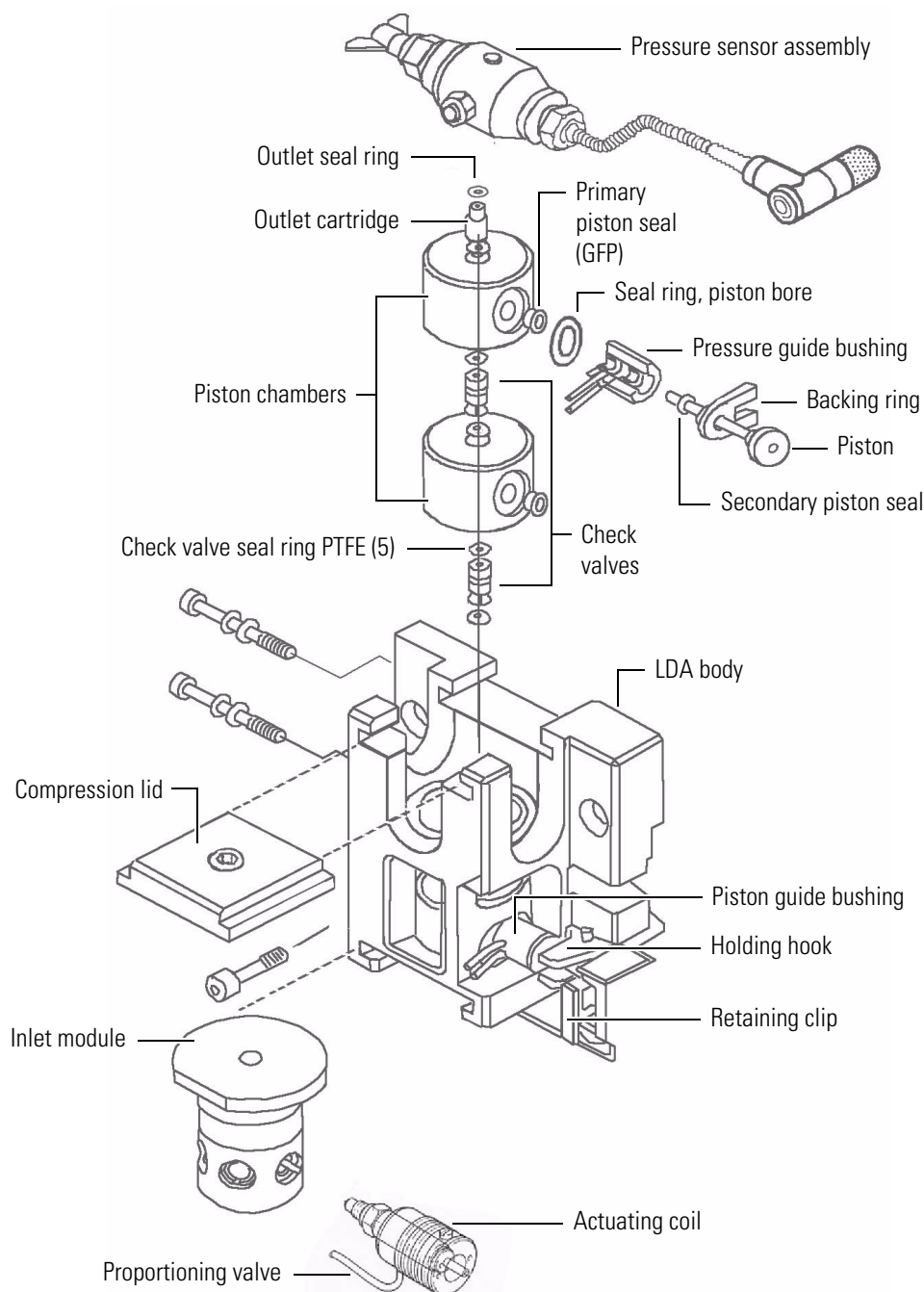

To service the liquid displacement assembly (LDA), follow these procedures:

1. [Removing the LDA from the Pump](#)
2. [Disassembling the LDA](#)
3. [Cleaning the LDA Components](#)
4. [Replacing the Primary Piston Seals](#)
5. [Reassembling the LDA](#)
6. [Reinstalling the LDA](#)

Removing the LDA from the Pump

The must have the following tools to remove the LDA from the pump:

- 4 mm balldriver (with the red screwdriver style handle) (P/N 00725-00032)
- 4 mm Allen wrench (P/N 000725-00034)
- Flat-blade screwdriver

❖ To remove the LDA from the pump

1. Turn off the pump.
2. Remove the crossover tube from the LDA by unscrewing the FingerTight fitting. See [Figure 30](#).
3. Disconnect the pressure sensor cable ([Figure 30](#)) by unscrewing it counterclockwise and pulling it forward.
4. Use the Allen wrench to pry off the retaining clips that secure the pistons to the motor drive arms. Place one end of the wrench behind the lip of the clip, and then push the other end of the wrench toward the pump face. See [Figure 31](#).
5. Raise the solvent filter in each bottle above the solvent level so that only the fluid in the lines drains out. Use a beaker to collect the mobile phase contained in the lines.

6. Unscrew the solvent lines (1/8 in. ID Teflon tubing) connected to the four solvent proportioning valves.

Figure 30. Front of MS pump, showing the crossover tube and the pressure sensor cable

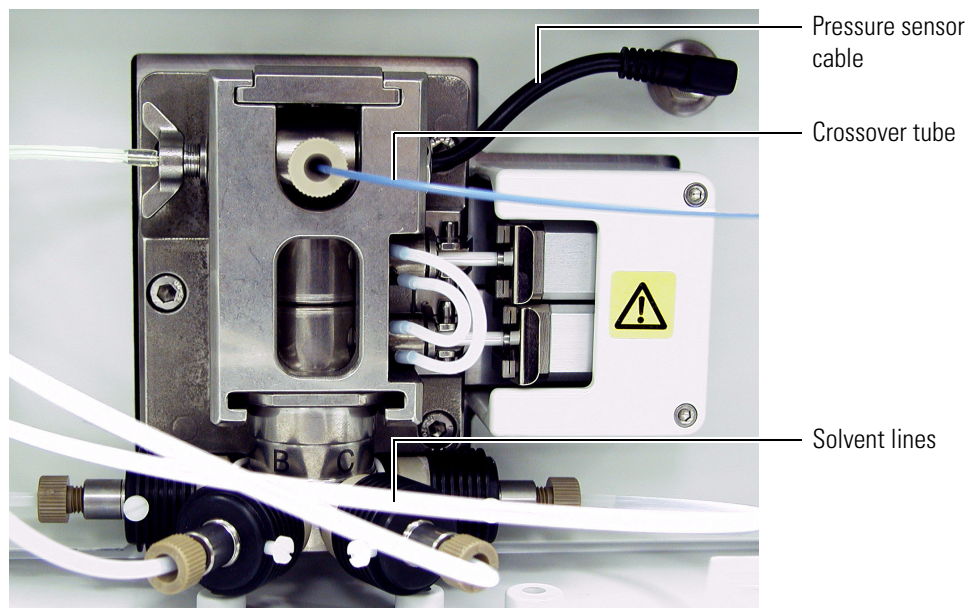
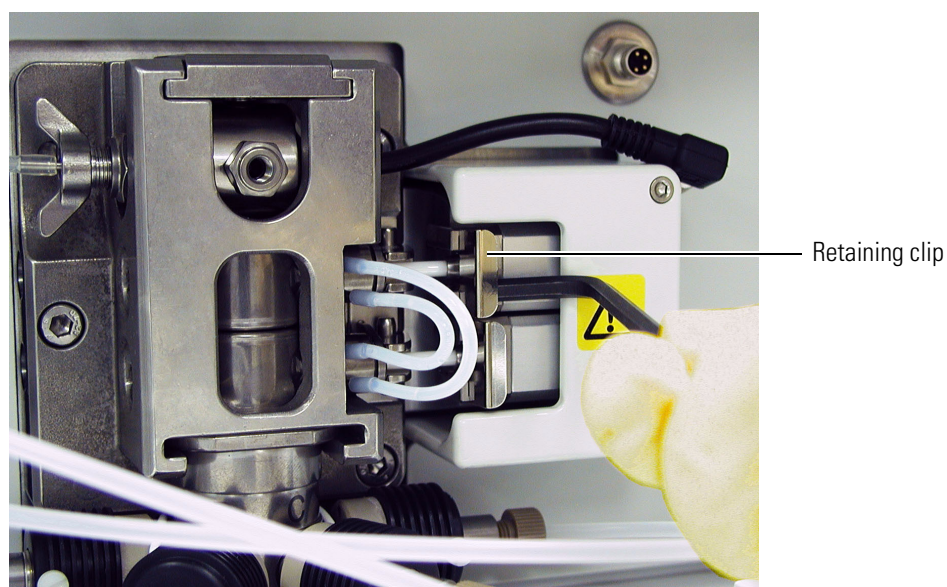

Figure 31. Using leverage to remove the piston spring clips



7. Detach the LDA from the pump by loosening the three captive screws securing the LDA body to the front of the pump. Carefully pull the LDA away from the pump by 8 to 10 cm (3 to 4 in.). See [Figure 32](#).

You cannot pull the LDA much farther away from the pump than this because the proportioning valve coils are connected to the pump by wires. See [Figure 33](#).



CAUTION Take care not to pinch the wires that connect the coils to the MS pump. Pinching a connecting wire can irreversibly damage the thin electrical wire housed within the white insulating coating. The damage might not be apparent until you attempt to run the MS pump.

Note Ideally your Surveyor MS Pump Plus is located on a clean, accessible benchtop where you can perform maintenance. If, however, your MS pump is located in an area in which it is inappropriate or difficult to perform maintenance, remove the LDA from the pump and place it on a clean, accessible benchtop before you disassemble it.

8. If necessary, remove the LDA from the pump. Use a flat-blade screwdriver to loosen the proportioning valve coils, and then pull the coils off the valves.

Figure 32. Location of the three captive screws

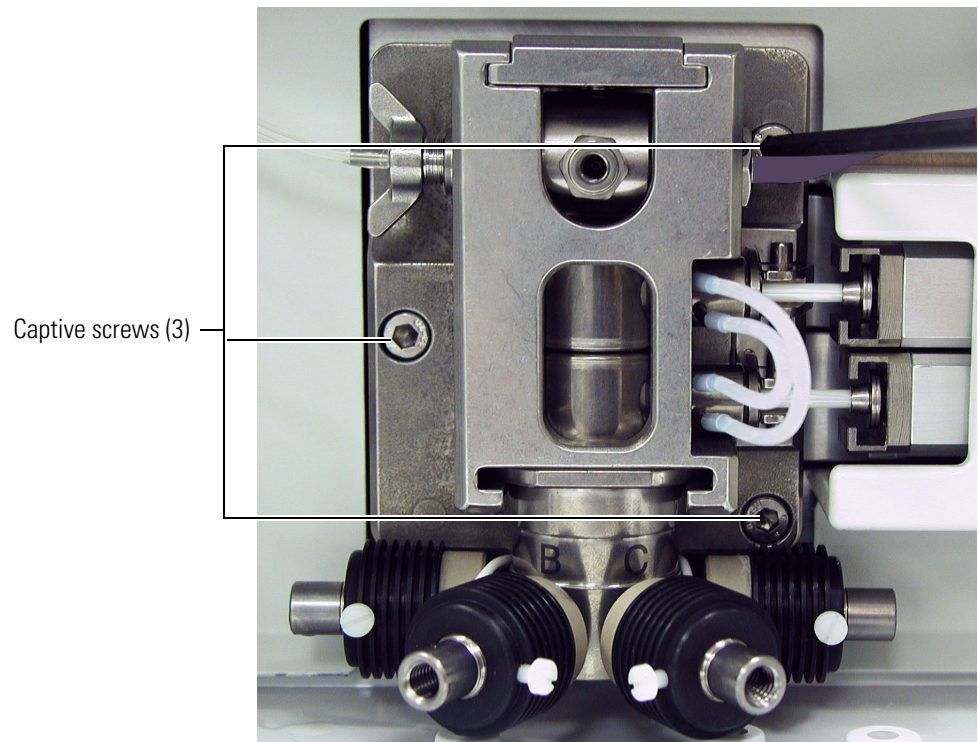
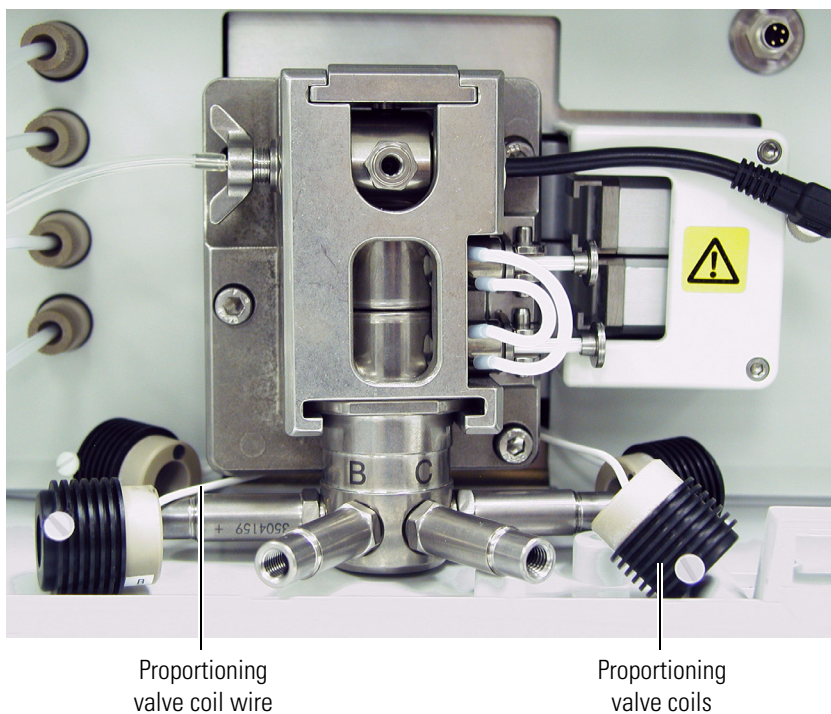

Figure 33. Removing the proportioning valve coils



Disassembling the LDA

To prevent contamination of the internal surfaces of the LDA, make sure that you have a clean benchtop to work on before you disassemble the LDA.

❖ To disassemble the LDA

1. Use the 4 mm balldriver to loosen the top setscrew, and then slide the LDA compression lid out. See [Figure 34](#).

Figure 34. Removing the LDA compression lid

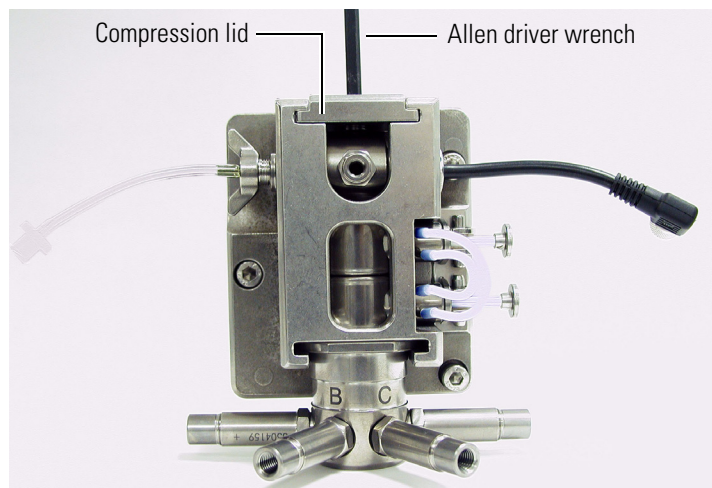

2. Remove the pressure sensor assembly by lifting it up and away from the LDA. See [Figure 35](#).

Figure 35. Removing the pressure sensor assembly

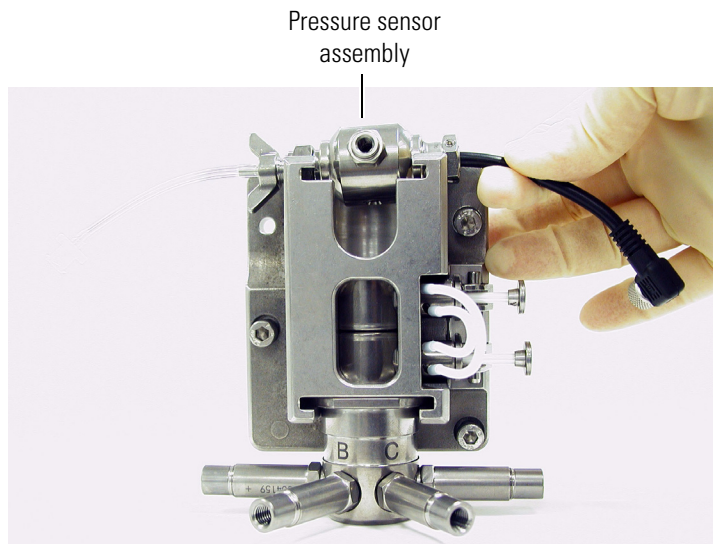

3. Remove the two pistons by pulling them to the right. See [Figure 36](#).
4. Use the 4 mm balldriver to loosen the fastening screws. The fastening screws are on the left side of the LDA and are attached to the holding hooks. See [Figure 37](#).

Figure 36. Removing the pistons from the LDA

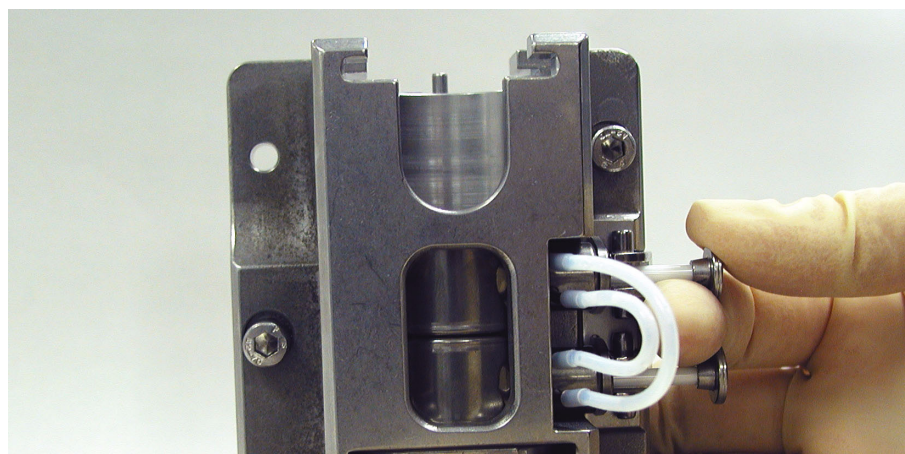
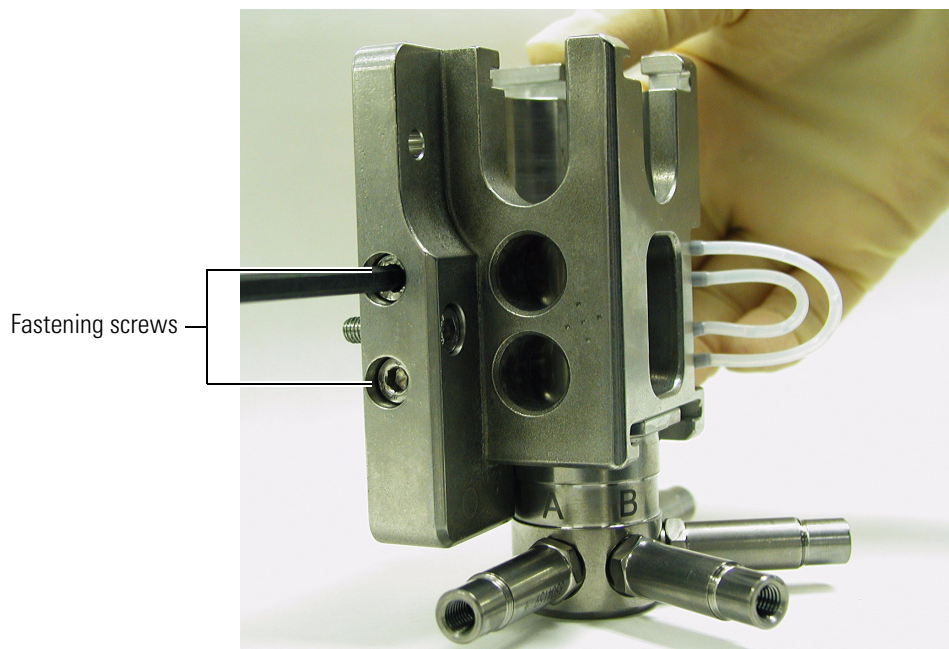
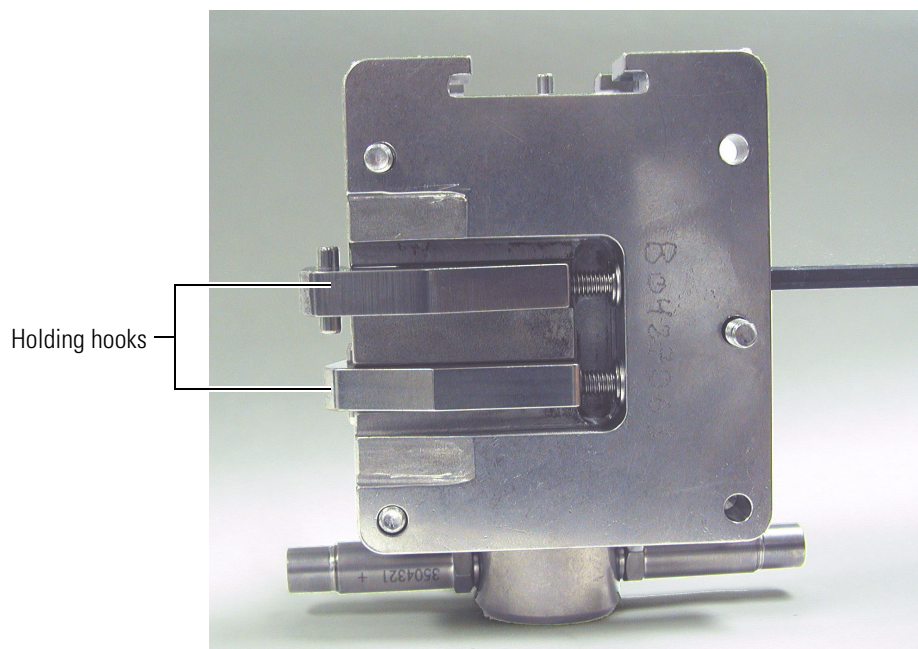

Figure 37. Loosening the two fastening screws



To provide enough clearance to remove the piston guide bushings, loosen the screws by at least six turns. As you loosen the screws, the holding hooks move to the right. If you prefer, you can detach the holding hooks completely with approximately nine turns on the screw fasteners. See [Figure 38](#).

Figure 38. View of loosened holding hooks



5. Remove the piston guide bushings and backing rings and place them on a clean surface. See [Figure 39](#).

Figure 39. Removing the piston guide bushings

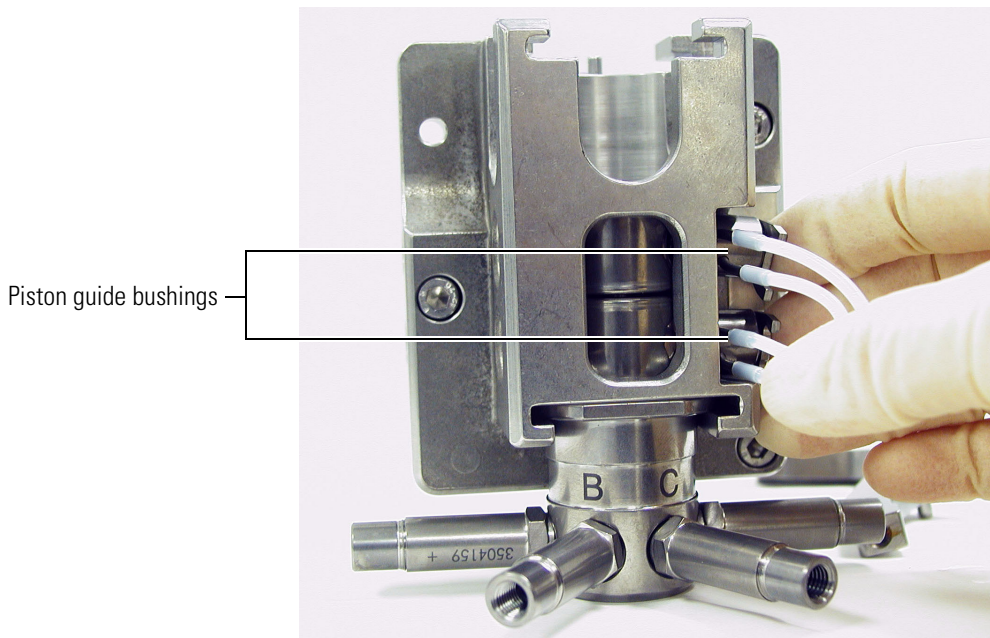

6. Slide the two piston chambers out of the LDA body. To prevent canting, (tilting out of alignment, which can cause the piston chambers to get wedged within the inner cylinder of the LDA body) keep the piston chambers together as you remove them from the LDA body. See [Figure 40](#).

Figure 40. Removing the piston chambers

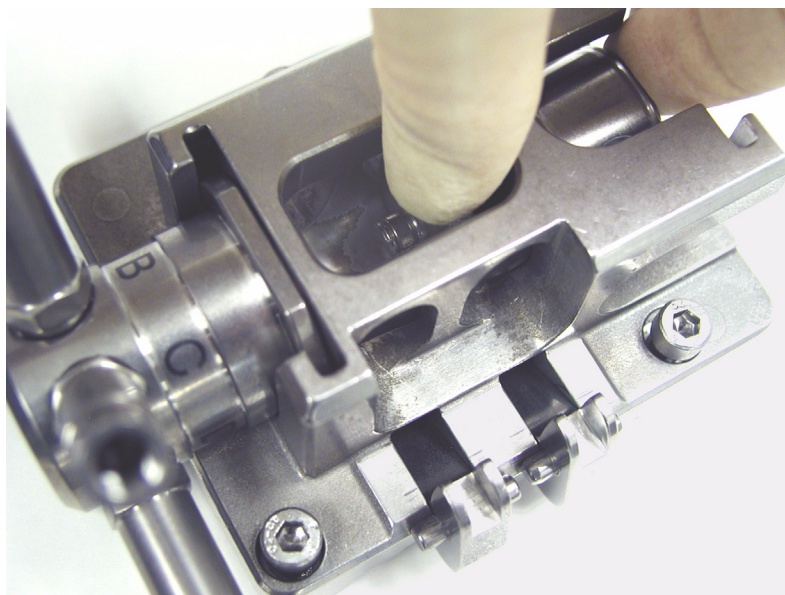

Cleaning the LDA Components

You can clean most LDA components without disassembling the LDA simply by running the pump for one hour with an appropriate solvent on all four channels (see “Cleaning the LDA Components without Disassembling the LDA” on page 38).

After you disassemble the LDA, concentrate on cleaning the following components:

- Check valves (see “Cleaning the Check Valves,” below)
- Pistons (see “Cleaning the Pistons” on page 48)
- Piston chambers and inlet module (see “Cleaning the Piston Chambers and the Inlet Module” on page 48)

These are the most likely components to have problems with contamination. The primary piston seals cannot be cleaned. If the primary piston seals contain particulate matter, replace them.

Cleaning the Check Valves

To clean the check valves, Thermo Fisher Scientific recommends using a 10 mL syringe with a very short piece of silicon tubing at the Luer exit. See Figure 41. With this syringe, gently flush the check valves with the following solvents: 5 mL acetone, followed by 5 mL of distilled water with a few drops of detergent, and then 5 mL methanol. If you cannot achieve free flow through the check valve, replace it.



CAUTION Thermo Fisher Scientific does not recommend cleaning check valves with an ultrasonic bath, because this procedure does not always extract fibrous particles from the check valves. You might even damage the small ruby balls inside by using an ultrasonic bath.

Figure 41. Cleaning the check valve



Cleaning the Pistons

If precipitate is visible on the pistons (P/N 00201-11324), clean them with a soft tissue and cleaning paste. See [Figure 42](#).

Figure 42. Cleaning a piston

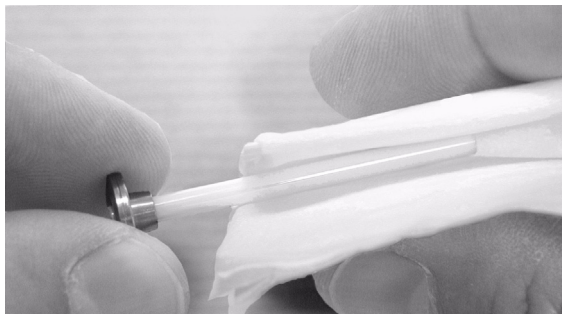

Cleaning the Piston Chambers and the Inlet Module

Clean the piston chambers if the primary piston seals have started to decompose and you notice black, fibrous, particles in the chamber.

❖ To clean the piston chambers and the inlet module

1. Insert the seal removal tool into the used primary piston seal. Use a twisting motion to pry the seal out of the piston chamber. See [Figure 43](#). The primary piston seals cannot be reused. After you remove them from the piston chamber, throw them away.

Figure 43. Removing the used primary piston seal



Note Each side of the piston chambers and the top bore of the inlet module contain a check valve seal ring for a total of five seal rings. Inspect the seal rings inside the top and the bottom of the piston chambers.

2. Use a needle to remove the check valve seal rings (P/N 00107-18118) as shown in [Figure 44](#). Be careful not to scratch the piston chamber with the needle as you remove its seal ring, as scratching the piston chamber might cause leaking.

Figure 44. Using a needle to remove the check valve seal ring

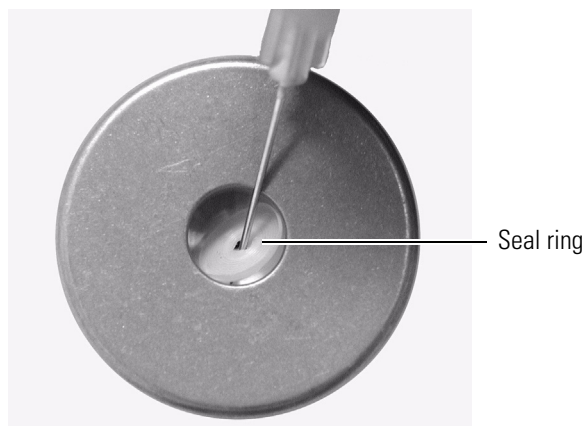

3. Place the piston chambers and the inlet module in an ultrasonic bath. First use water (to remove any buffer precipitate) and then use acetone.
4. After cleaning the piston chambers and the inlet module, reinstall the seal rings if they do not show signs of damage. Unlike the seal rings, the primary piston seals cannot be reused. Replace the primary piston seals before reassembling the LDA.

Go on to the next topic: [Replacing the Primary Piston Seals](#).

Replacing the Primary Piston Seals

You must replace the primary piston seals when you disassemble the LDA.

❖ To replace the primary seals

1. Soak a pair of new primary piston seals (springs up) for five minutes in methanol. Soaking the seals removes air from the springs.



CAUTION Do not place the seals in an ultrasonic bath. Placing the seals in an ultrasonic bath can ruin the smooth surface of the seals.

2. If you have not already done so, do the following:
 - a. Remove the LDA from the pump (see [“Removing the LDA from the Pump”](#) on [page 40](#)).
 - b. Disassemble the LDA (see [“Disassembling the LDA”](#) on [page 43](#)).
 - c. Remove the used piston seal (see [“Cleaning the Piston Chambers and the Inlet Module”](#) on [page 48](#)).

3. Install a new primary piston seal (P/N 00107-18110):
 - a. Create a seal insertion tool by inserting a clean piston into a piston guide bushing as shown in [Figure 45](#).

Figure 45. Seal installation tool (piston and piston guide bushing)

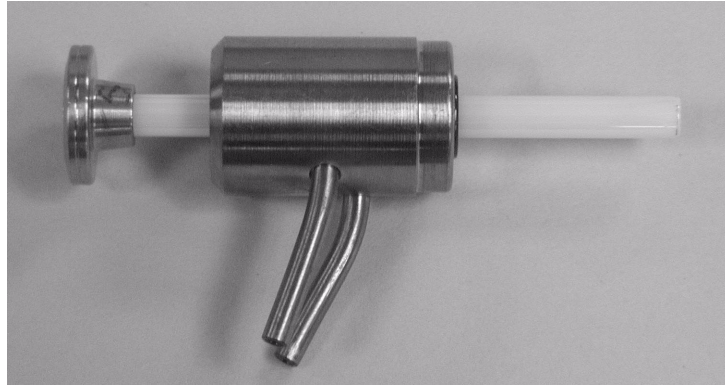

- b. Slide the new seal onto the piston. Be sure that the spring is facing out, so that it faces the piston chamber when the seal is installed in the chamber. See [Figure 46](#).

Figure 46. View of the spring face

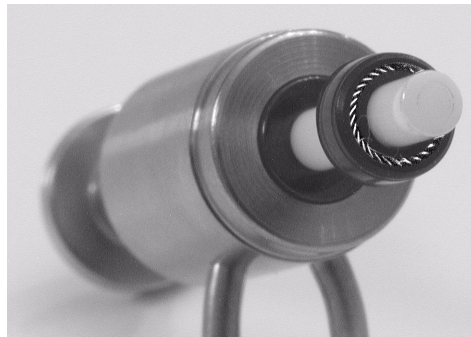

- c. Insert the piston, which is holding the seal, into the piston bore.
 - d. Push the end of the piston guide bushing into the piston bore to make sure that the seal is properly seated in the piston chamber. See [Figure 47](#) and [Figure 48](#).
4. Repeat steps 2 and 3 with the second piston chamber.

Figure 47. Pushing the piston guide bushing into the piston bore

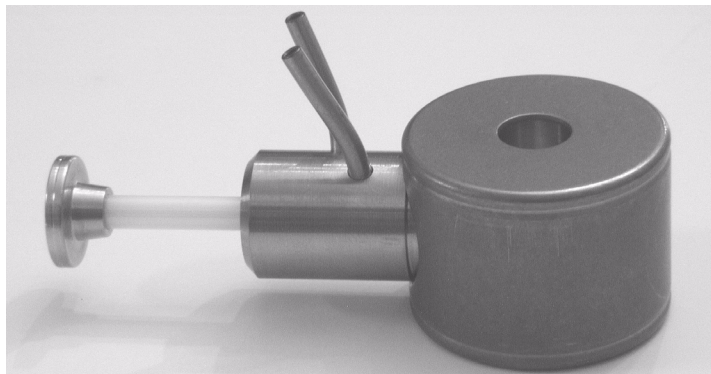

Figure 48. View showing the piston bore with a properly seated seal



Reassembling the LDA

The LDA is reassembled in three stages. First, the stacked components that fit within the LDA body are reinstalled. Next, the piston guide bushings, the backing rings, and the pistons are reinstalled. And finally, the compression lid and the left side fasteners are tightened with the 4 mm Allen wrench to prevent leaking.

❖ **To reassemble the LDA, follow these steps**

- [Step 1: Reinstalling the Stacked Components of the LDA](#)
- [Step 2: Reinstalling the Piston Guide Bushings and the Pistons](#)
- [Step 3: Tightening the LDA to Prevent Leakage](#)

If they are mounted correctly, the parts of the LDA form a perfect stack to ensure a smooth piston movement. A schematic diagram of the LDA is shown in [Figure 49](#).

Figure 49. LDA schematic diagram

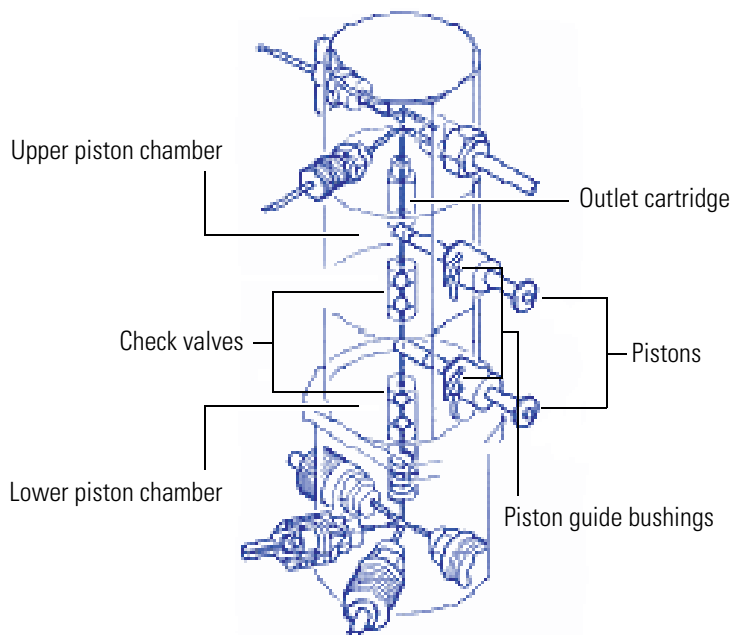

Step 1: Reinstalling the Stacked Components of the LDA

The stacked components of the LDA form a linear flow path from the inlet module on the bottom of the stack to the pressure sensor assembly on the top of the stack. See [Figure 50](#).

Figure 50. LDA stack components

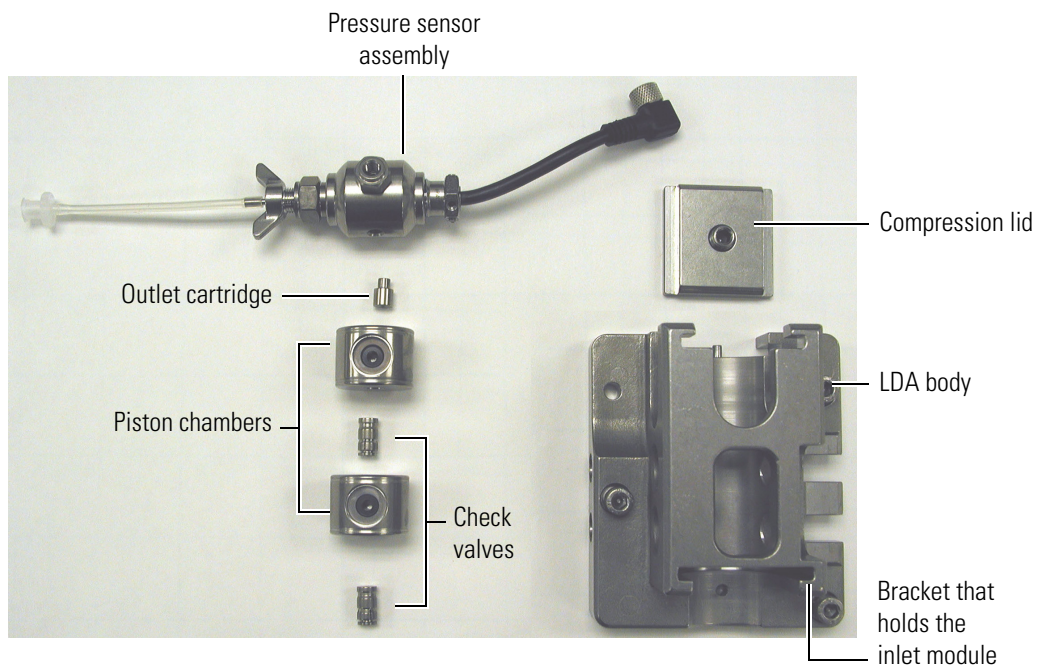

❖ **To reinstall the components of the stack**

1. Take a check valve (P/N 00110-05110), noting the flow direction (flow is from bottom to top of the LDA), and drop it into place in the inlet module. See [Figure 51](#) and [Figure 52](#).

Figure 51. Check valve, showing the flow direction

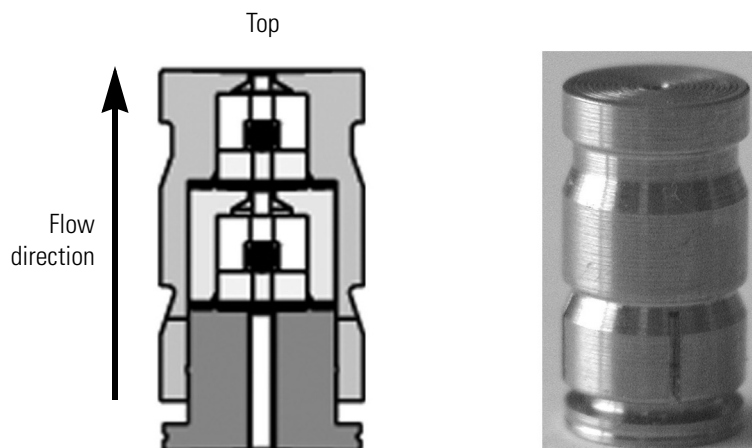
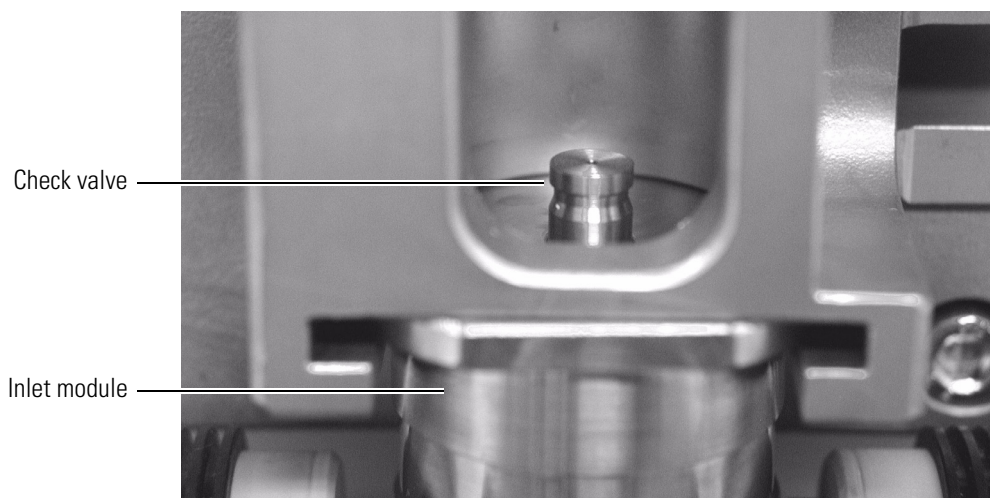
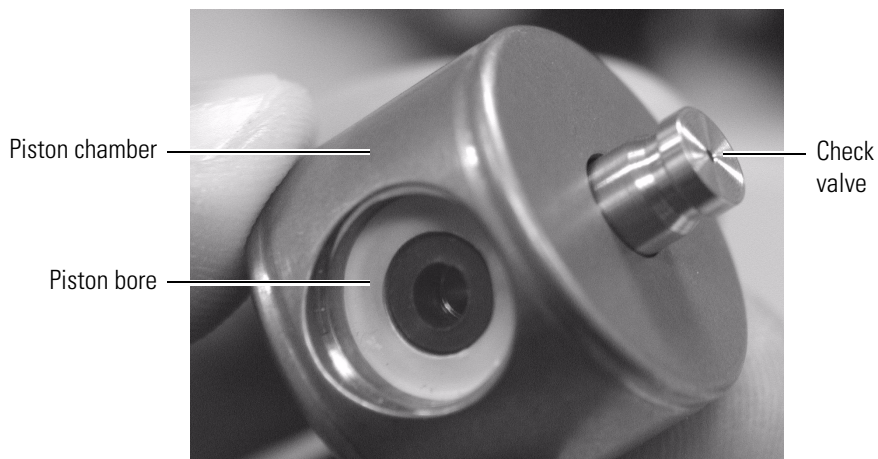

Figure 52. Inserting the check valve into the inlet module



2. To prevent canting of the chambers as you insert them into the LDA body, create a stack of the two piston chambers with the remaining check valve in the middle:
 - a. Drop the second check valve into the first piston chamber (noting flow goes up as [Figure 51](#) shows). See [Figure 53](#).

Figure 53. Inserting check valve into piston chamber



- b. Take the second chamber and slide it on top. Orient the second chamber so that its piston bore is aligned with the piston bore on the first chamber. See [Figure 54](#).

Figure 54. Aligning the piston chambers

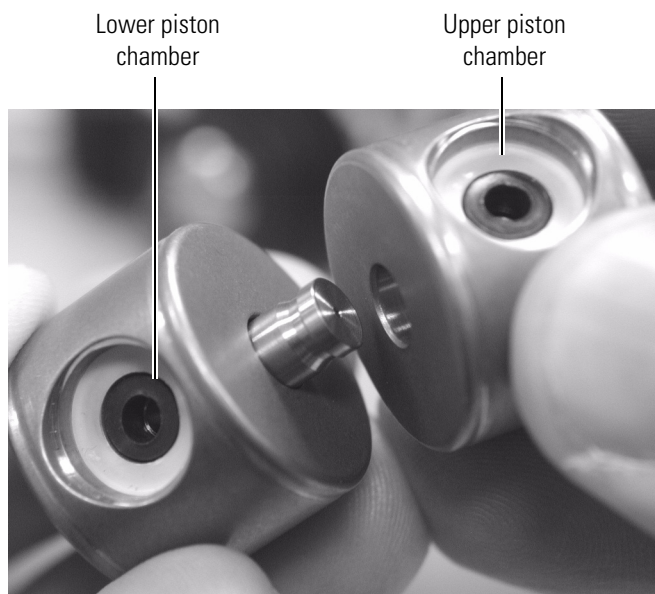

3. Slide the stacked piston chambers into the LDA body so that the piston bores are to the right. See [Figure 55](#). Ensure that the stack is oriented with the direction of flow from bottom to top.

Figure 55. Installing the piston chambers

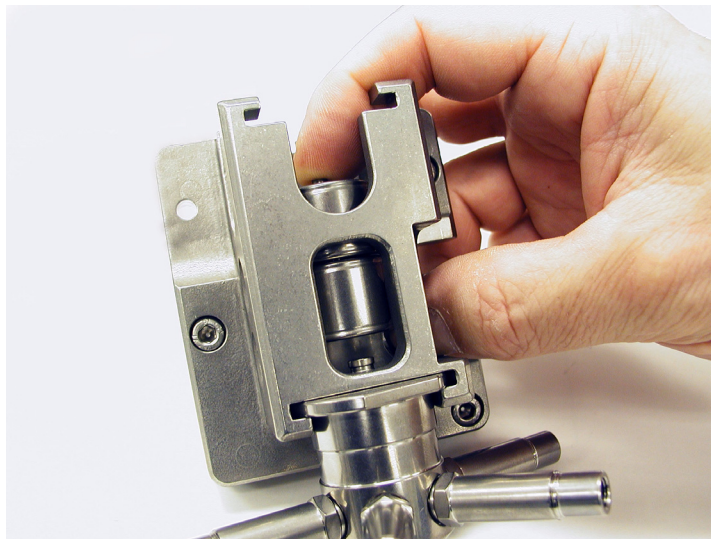

4. Insert the outlet cartridge, with the narrow end up, into the upper piston chamber. See [Figure 56](#).

Figure 56. Reinstalling the outlet cartridge

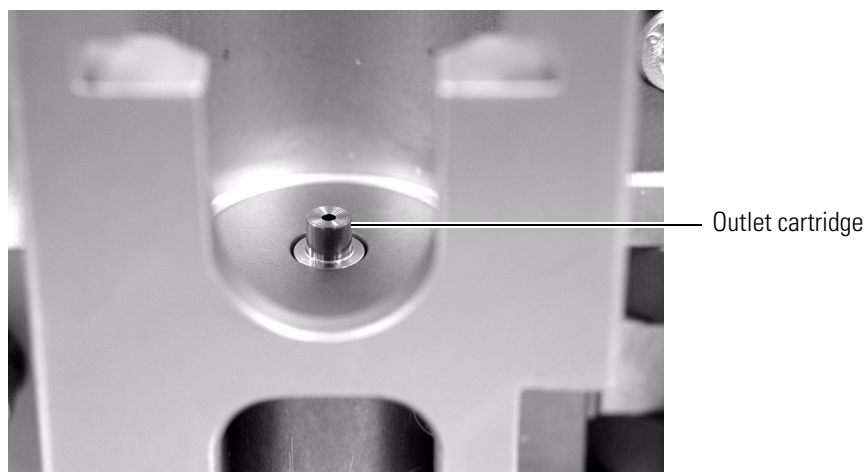

5. Align the bore on the bottom of the pressure sensor assembly with the outlet cartridge, and then set the pressure sensor assembly in place. See [Figure 57](#).

Figure 57. Installing the pressure sensor

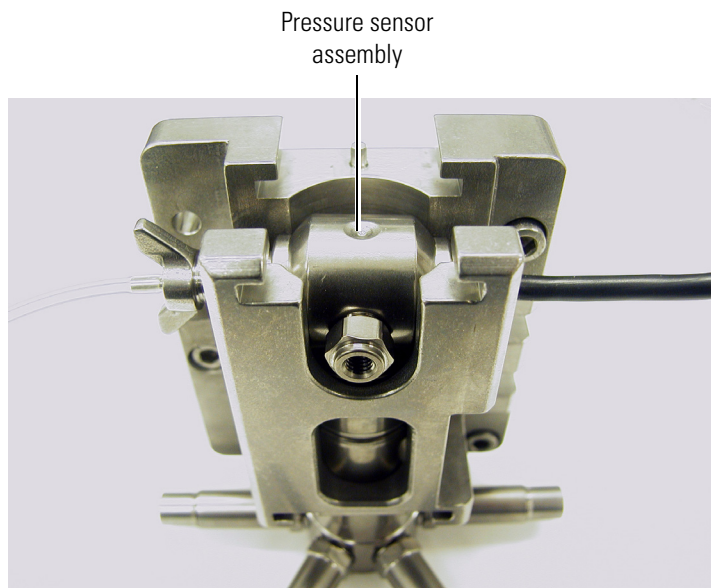

6. Slide the compression lid back into place. Tighten the screw until it is snug and then loosen it by half a turn. You tighten the screw later once the pistons and the piston guide bushings are in place. See [Figure 58](#).

Figure 58. Tightening the compression lid

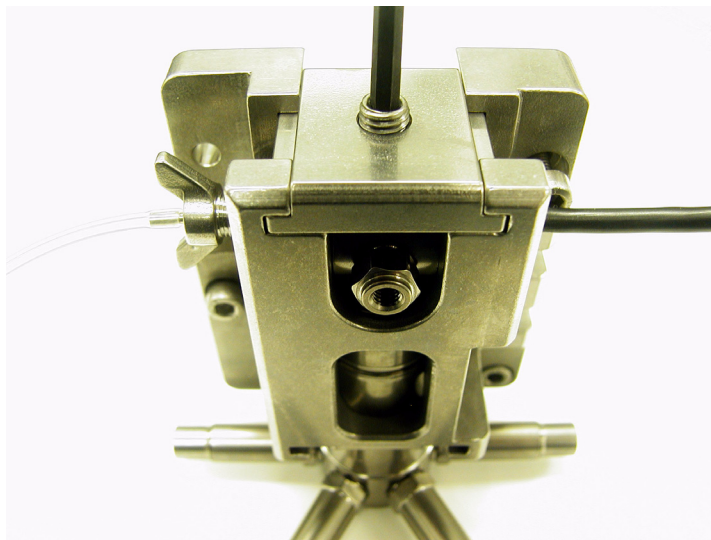

Step 2: Reinstalling the Piston Guide Bushings and the Pistons

After you have reinstalled the stacked components of the LDA, you are ready to reinstall the piston guide bushings and the pistons.

❖ **To install the guide bushings and the pistons**

1. Insert the piston guide bushings into the piston bores. The end of the piston guide bushing that contains the red ruby bearing fits into the piston bore. See [Figure 59](#).

Figure 59. Inserting the piston guide bushing into the piston bore

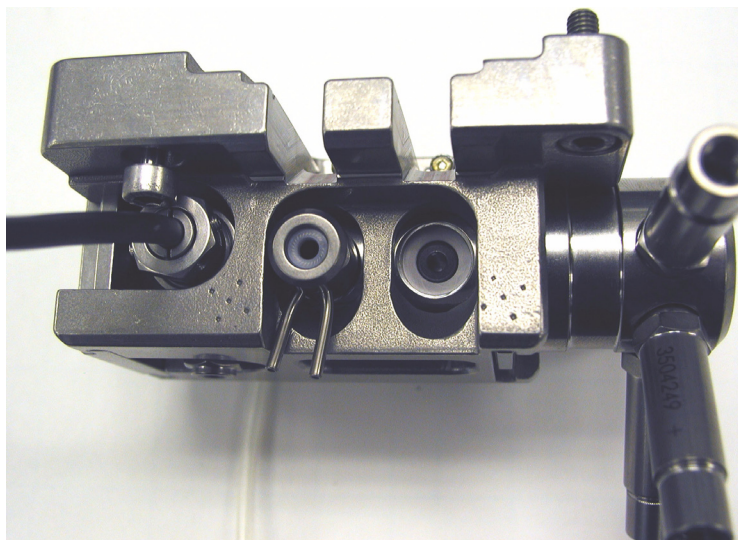

2. Insert the two A-shaped backing rings into the other end of the piston guide bushings. Make sure that the “legs” of the backing rings face toward the holding hooks as shown in [Figure 60](#).

Figure 60. Installing the backing rings

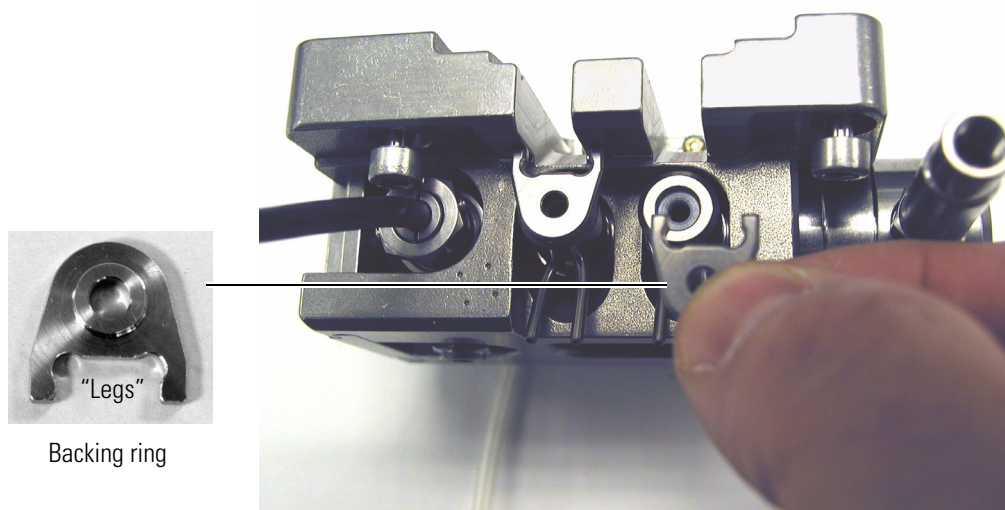

3. Alternately tighten the fasteners on the left side of the LDA until the holding hooks are close enough to prevent slippage of the piston guide bushings and the backing rings. See [Figure 61](#) and [Figure 62](#).

Figure 61. Tightening the left-side fasteners, as viewed from the back of the LDA body

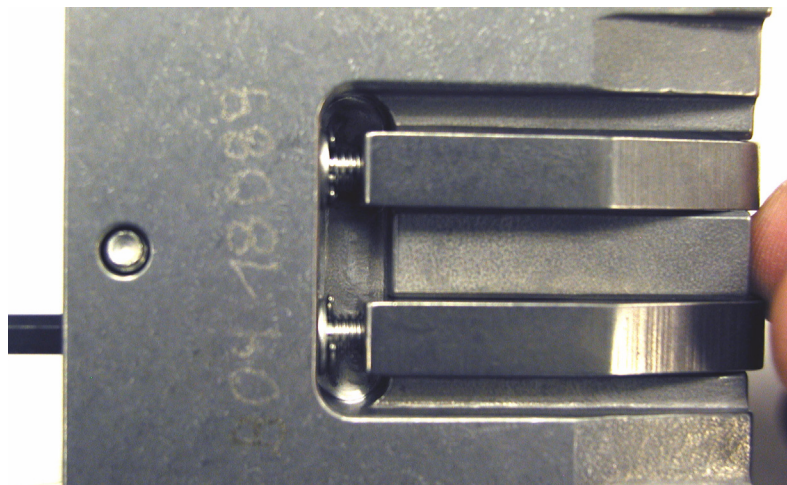
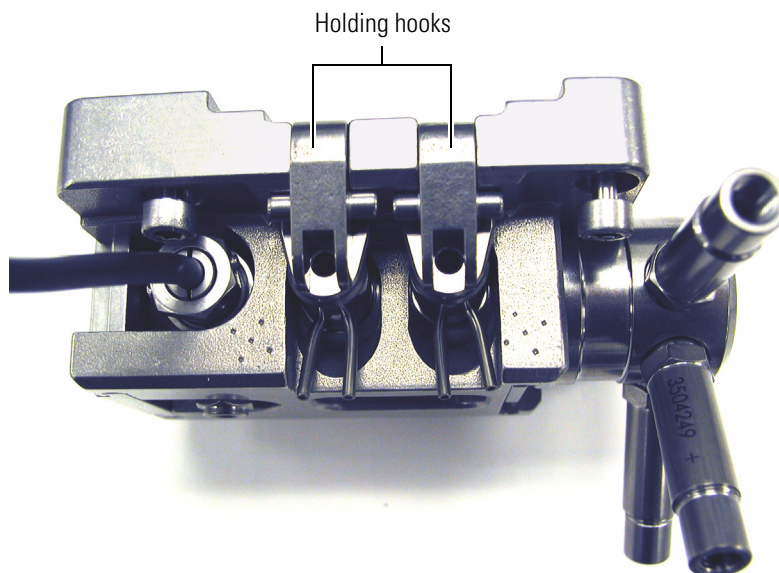
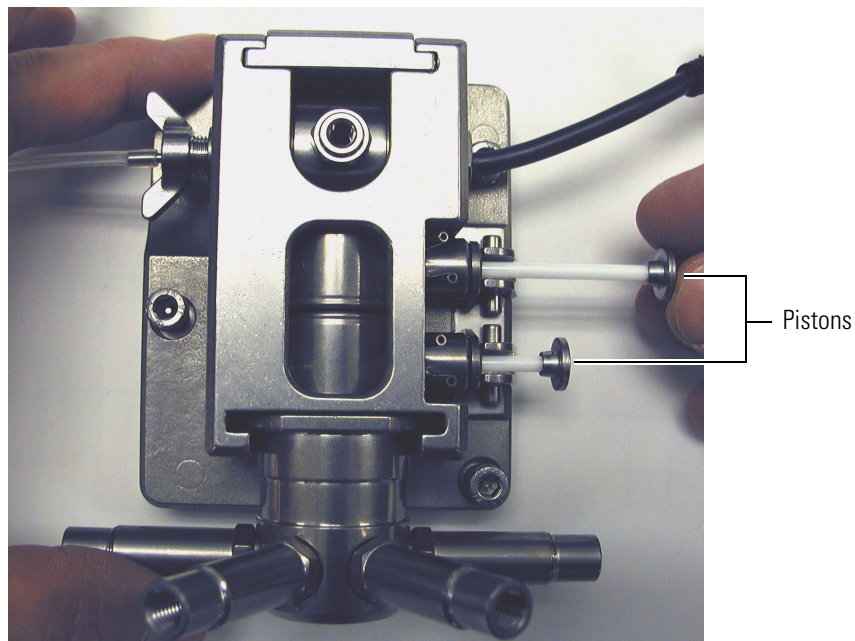

Figure 62. View of piston guide bushings and backing rings held snugly by holding hooks



4. Insert the two pistons into the holes in the backing rings. Continue to push them into the piston bores until they contact the bottom. As you push the pistons into the bores, you can feel interference due to the seals. If the pistons appear uneven, loosen the left side fasteners and readjust the pistons until they contact the bottom of the piston bores. See [Figure 63](#).

Figure 63. Installing the pistons



Step 3: Tightening the LDA to Prevent Leakage

After you have reinstalled all the components of the LDA, you are ready to perform the final tightening that prevents leakage.

❖ **To tighten the compression lid and the left side fasteners**

1. Using an Allen wrench, tighten the compression lid by an additional quarter to half turn, and then retest the piston movement. See [Figure 64](#).

Figure 64. Final tightening of the compression lid

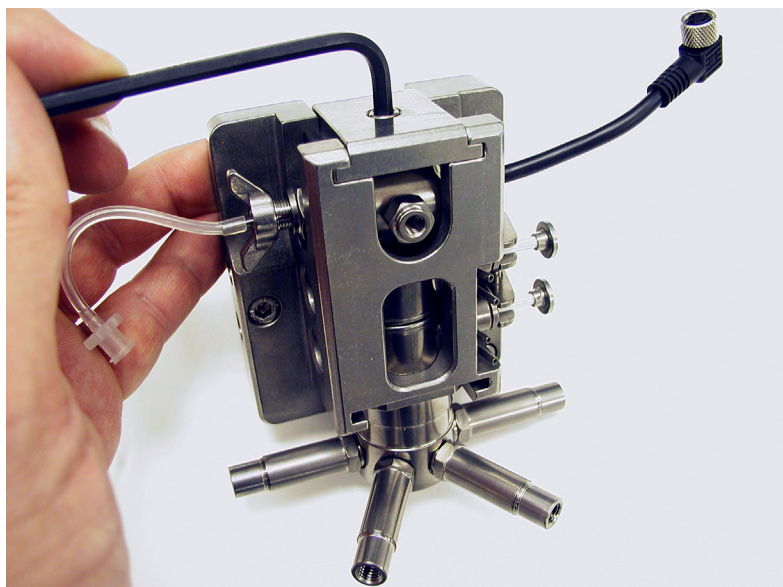

2. Using an Allen wrench, tighten the two left side fasteners by an additional quarter to half turn, and then verify that the pistons move in and out easily, but with some interference due to the seals. See [Figure 65](#).

Figure 65. Final tightening of the left-side fasteners

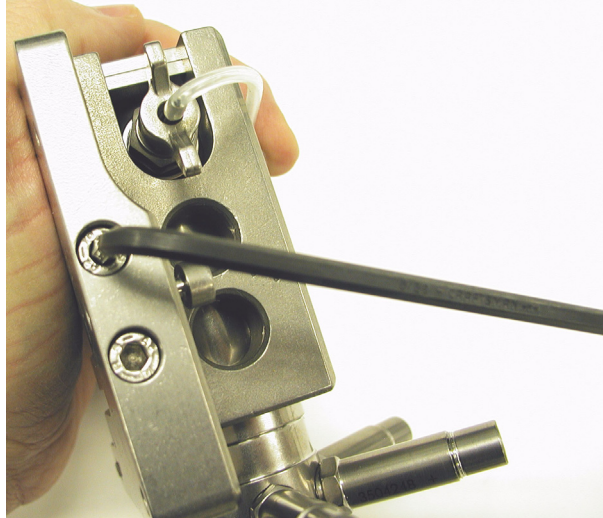

Reinstalling the LDA

After you reassemble the LDA, you are ready to reinstall the LDA onto the MS pump.

❖ To reinstall the LDA

1. Reattach the coils to the proportioning valves.
2. Position the LDA onto the front of the pump. The two guide pins on the pump drive align with the two mating bores on the LDA housing. Before you attach the LDA to the pump, make sure that the wires connected to the proportioning valve coils are located in the slot below the arm drive mechanism. See [Figure 66](#).



CAUTION Although the damage might not be visible, pinching one of these connecting wires can irreversibly damage the internal copper wire, which conducts electricity to magnetize the coil. This damage causes the proportioning valve to malfunction.

Figure 66. Positioning the LDA on the pump

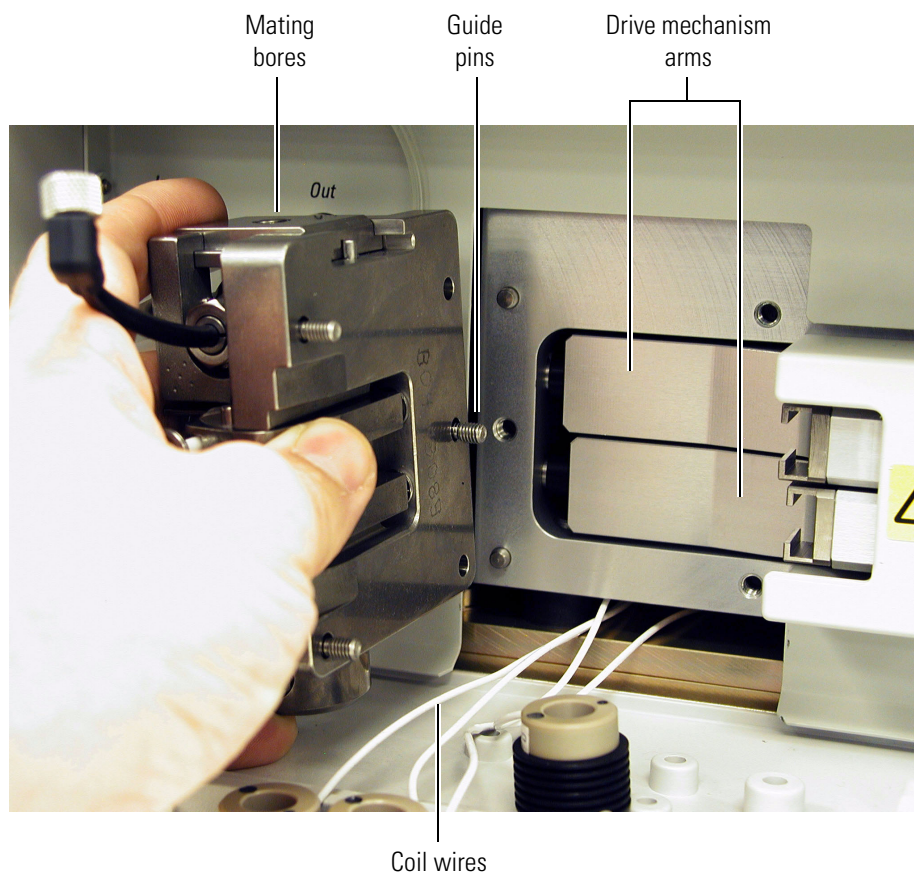

3. Alternately tighten the three captive screws that hold the LDA body to the pump. See [Figure 67](#).

Figure 67. Attaching the LDA to the pump

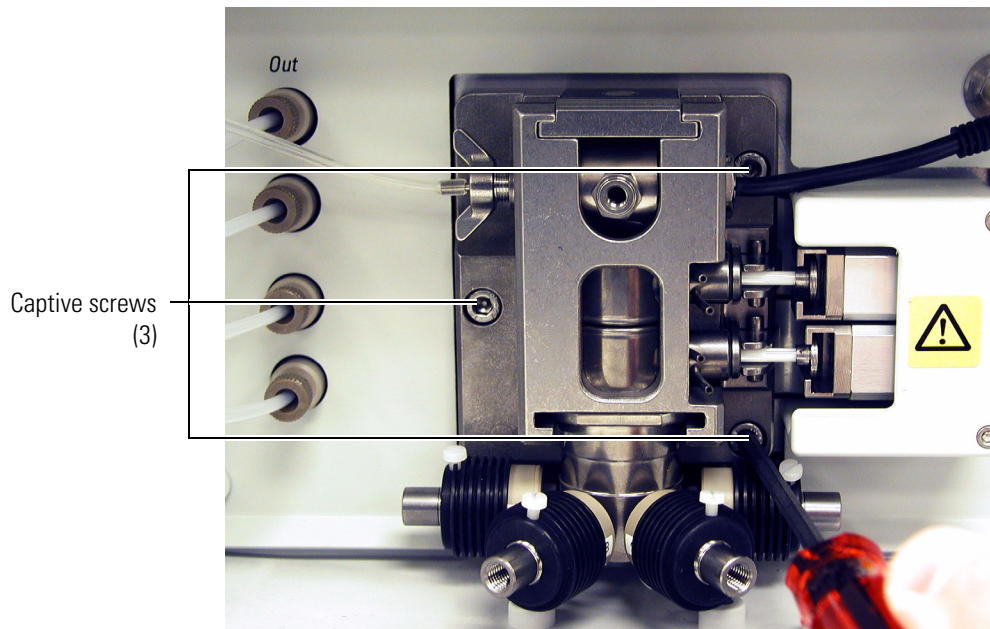

4. Push the piston heads toward the arms of the drive mechanism. Leave a gap for the piston retaining clips between the piston head and the brackets at the ends of the arms. See [Figure 68](#).

Figure 68. Pushing the piston heads toward the drive mechanism arms

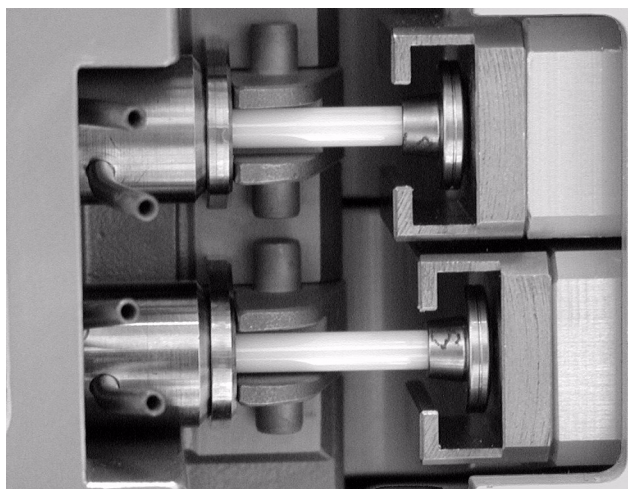

5. Insert the two piston retaining clips between the piston heads and the brackets of the drive mechanism arms. See [Figure 69](#).

Figure 69. Installing the piston retaining clips

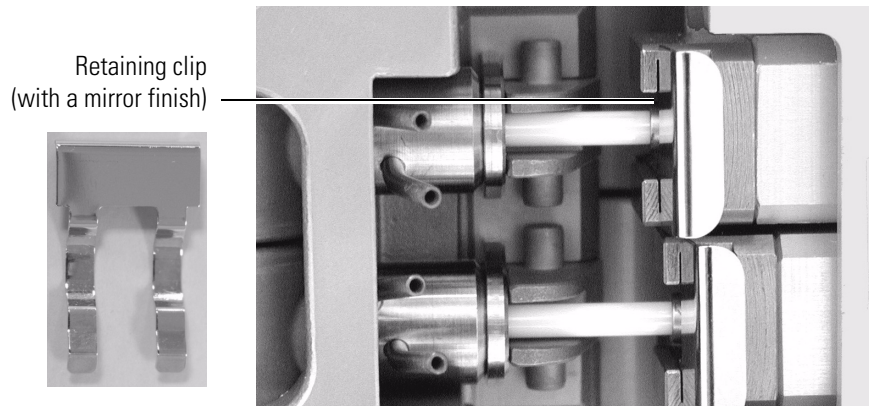

6. Reconnect the following:
 - Connect the pressure sensor cable to the pump (see [Figure 70](#)).
 - Connect the crossover tube to the pressure sensor assembly (see [Figure 70](#)).
 - Connect the solvent lines to the four proportioning valves (see [Figure 70](#)).
7. Turn on the solvent flow and check for leaks.
8. Perform the pump pulsation and proportioning tests described in [Chapter 3, “Diagnostics,”](#) to ensure that your pump is functioning properly.

Figure 70. Completed assembly

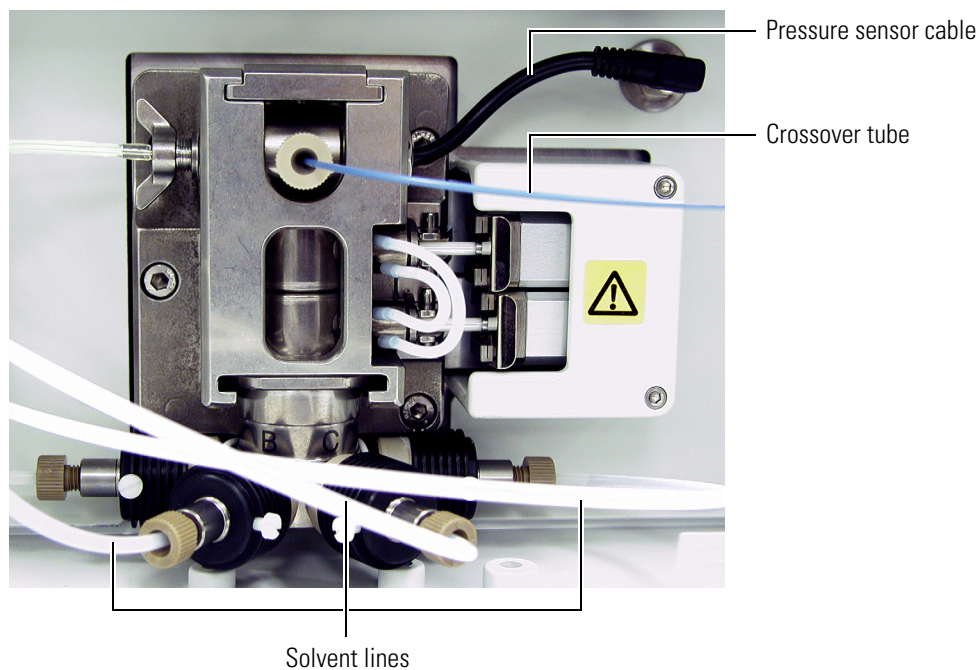

Servicing the Proportioning Valves

Each proportioning valve of the Surveyor MS Pump Plus contains an electromechanically actuated ball and seat valve. The ruby ball portion of the valve sits on one end of a magnetic piston that floats within the body of the valve. The sapphire seat, against which the ball rests, is located on the backside of the valve face. See [Figure 71](#).

The ruby ball normally rests against the sapphire seat, shutting off the solvent flow. Electrical pulses from the coils surrounding the valve cause the magnetic piston to glide back and forth within the body of the valve, allowing solvent to flow through the valve and into the inlet module.

Figure 71. Ruby ball and sapphire seat

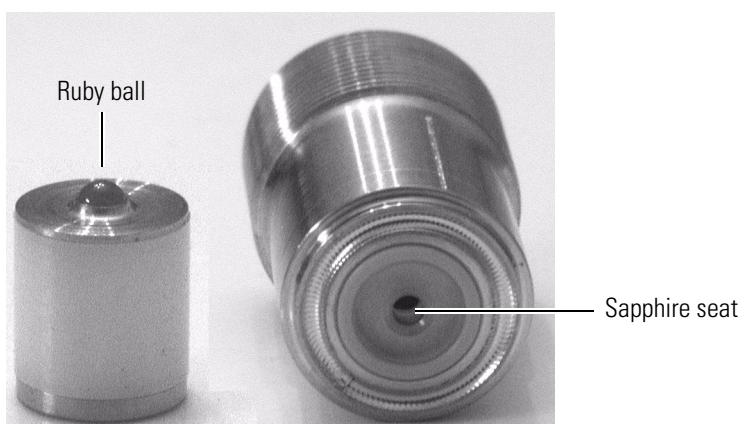

Occasionally, after extended periods of disuse, the free-floating piston inside the proportioning valve freezes against its sapphire seat. When this occurs, dislodging the frozen valve requires a greater mechanical force than the magnetic field applied by the actuating coils.

You can dislodge the free-floating piston inside the valve with the proportioning valve tool supplied in the accessory kit. See [Figure 72](#). This tool fits through the solvent inlet in the end of the valve face. Push the tool (which is a piece of stainless steel wire) into the valve until you contact the piston, and then gently push the piston away from the valve face.

Figure 72. Proportioning valve, shown with the valve tool



Replacing the Solvent Reservoir Filter

The solvent reservoir filter removes particulate matter from the mobile phase before it enters the solvent line. Eventually particulate matter from the mobile phase builds up on the filter and restricts the flow of solvent. A clogged solvent reservoir filter can cause the formation of air bubbles in the solvent line, erratic flow rates, and an abnormally low system backpressure.

To determine if the solvent reservoir filter is clogged, remove the filter from the solvent line and monitor the system backpressure as the pump draws solvent into the solvent line. If the pressure trace is normal in the absence of the solvent reservoir filter, replace the filter.

Thermo Fisher Scientific offers two solvent reservoir filters: a 10 micron pore size Teflon filter (P/N A4258-010) and a 10 micron pore size stainless steel filter (P/N A4929-010). [Figure 73](#) shows the Teflon® filter.

Figure 73. Solvent reservoir filter and solvent line

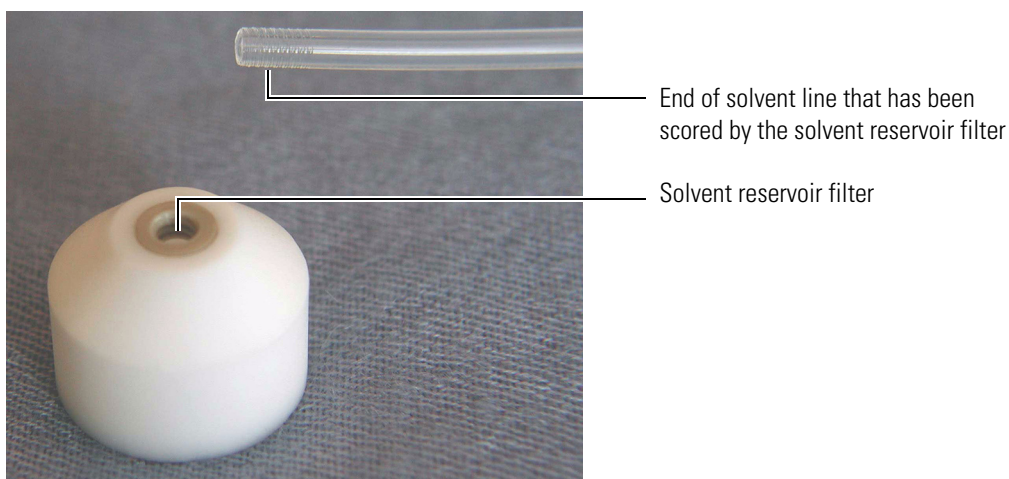

4 Maintenance

Replacing the Solvent Reservoir Filter

Troubleshooting

If properly maintained, the Surveyor MS Pump Plus can operate free of trouble for many years. Most pump problems can be avoided by simple, periodic maintenance, as described in [Chapter 4, “Maintenance.”](#) However, in the event that an error message is displayed or if a mechanical or electrical failure is suspected, you might be able to diagnose the source of the problem. If the diagnosis indicates that a problem exists with serviceable parts inside the pump, contact a Thermo Fisher Scientific service representative.

Contents

- [Troubleshooting Tips](#)
- [General System Troubleshooting](#)
- [Surveyor MS Pump Troubleshooting Guide](#)
- [Pump Pulsation](#)
- [Baseline Noise at Low Pressures \(under 40 Bar\)](#)
- [Insufficient Solvent Flow from the Pump Outlet](#)
- [Irreproducible Retention Times](#)

For more detailed chromatographic troubleshooting, see any HPLC troubleshooting reference book or call your Thermo Fisher Scientific service representative.

Troubleshooting Tips

Begin the diagnosis of the problem by performing the following steps:

Eliminate all other possible sources of trouble. Before you invest time trying to diagnose a suspected pump problem, you should verify that the pump is the only source of difficulty. Systematically eliminate all other instruments in your Surveyor HPLC system as the source of trouble. If you are not sure which component of your chromatography system is responsible for poor system performance, see [“General System Troubleshooting”](#) on [page 68](#) for some useful suggestions.

When you are sure that it is the pump. When you have isolated the pump as the only remaining source of difficulty, proceed to the troubleshooting table for help in determining the exact cause of the problem.

General System Troubleshooting

The following section can be helpful in the initial investigation of a problem with the Surveyor Plus HPLC system.

❖ **No flow**

1. Check mobile phase connections.
2. Check for leaks.
3. See problem 8 on [page 72](#).

❖ **High Backpressure**

1. Check flow rate and system/column specifications.
2. Check for tubing or column blockage.
3. Check for blockage in the injection valve.
4. See “[Surveyor MS Pump Troubleshooting Guide](#)” on [page 70](#).

❖ **Unstable Baseline or Drift**

1. System column not equilibrated; allow more equilibration time.
2. Refer to the troubleshooting guide for your detector.
3. See problem 7 on [page 71](#).

❖ **Baseline Noise**

1. Check for air bubbles in the system.
2. Check for system solvent contamination.
3. The pulse dampener is contaminated; prime the pulse dampener.

❖ **No Peaks**

1. Check the detector and data system connections.
2. Refer to the troubleshooting guide for your autosampler.
3. Check sample retention with chromatographic conditions.
4. See problem 8 on [page 72](#).

❖ **Contaminating / Ghost Peaks**

1. Clean the system and the column.
2. Refer to the troubleshooting guide for your autosampler.

❖ **Poor Peak Shape**

1. Check the system for leaks.
2. Check the fittings and tubing lengths.
3. Check the column performance.
4. Refer to the troubleshooting guide for your autosampler.
5. Refer to the troubleshooting guide for your detector.

❖ **Poor Retention Time Reproducibility**

1. Check the system for leaks and bubbles.
2. System/column not equilibrated and more time should be allowed.
3. Check the column performance.
4. Refer to the troubleshooting guide for your detector.
5. See problem 7 on page [page 71](#).

❖ **Poor Peak Area Reproducibility**

1. Check the column performance.
2. Refer to the troubleshooting guide for your autosampler.

❖ **No Instrument or Device Control**

1. Check the cable connections.
2. Check the system configuration.
3. Refer to the troubleshooting guide for each instrument.

Surveyor MS Pump Troubleshooting Guide

The information in [Table 4](#) can help you to identify specific pump-related problems.

Table 4. Troubleshooting pump related problems

Problem	Cause	Diagnostic/Remedy
1. No response when power is switched on	a. Power cord not firmly installed	a. Reseat power cord
	b. Power cord defective	b. Replace cord
	c. Power entry module fuse is blown	c. Replace fuse (See Figure 74)
2. LEDs not illuminated	a. LED PCB defective	a. Contact Thermo Fisher Scientific service representative
	b. Loose LED cable	b. Reseat LED connector
3. Pump motor does not run	a. Max pressure set to zero	a. Change max pressure in Instrument Setup and/or Direct Control
	b. Motor defective	b. Contact Thermo Fisher Scientific service representative
	c. Motor cable disconnected	c. Contact Thermo Fisher Scientific service representative
	d. Defective drive circuit	d. Contact Thermo Fisher Scientific service representative
	e. Internal fuse blown	e. Contact Thermo Fisher Scientific service representative

Table 4. Troubleshooting pump related problems, continued

Problem	Cause	Diagnostic/Remedy
4. Incorrect solvent composition	a. Proportioning valve dirty	a. Clean with acetic acid
	b. Proportioning valve cable loose	b. Reattach proportioning valve cable
	c. Proportioning valve timing not properly set	c. Contact Thermo Fisher Scientific service representative
	d. Proportioning valve defective	d. Contact Thermo Fisher Scientific service representative
	e. Proportioning valve drive circuit defective	e. Contact Thermo Fisher Scientific service representative
5. Pump does not start or stop remotely	a. Incorrect connection of synchronization cable	a. Reconnect synchronization cable
6. Proportioning valves do not click	a. Proportioning valve cable loose	a. Reattach proportioning valve cable
	b. Proportioning valve defective	b. Contact Thermo Fisher Scientific service representative
	c. Proportioning valve drive circuit defective	c. Contact Thermo Fisher Scientific service representative
	d. Proportioning valves are stuck	d. See “Servicing the Proportioning Valves” on page 64
7. Erratic flow rate	a. Restricted inlet tubing	a. Replace inlet tubing
	b. Restricted outlet tubing	b. Replace outlet tubing
	c. Dirty proportioning valve	c. Clean with acetic acid or replace proportioning valves
	d. Dirty check valve	d. Clean with acetic acid or replace check valves
	e. Leaking piston seal	e. Replace piston seals

Table 4. Troubleshooting pump related problems, continued

Problem	Cause	Diagnostic/Remedy
8. No flow	a. Loose or disconnected solvent lines	a. Check for leaks in the solvent lines at the degassing inlets and outlets, the proportioning valve inlets, and the crossover tube connections
	b. Excessive air in the solvent lines	b. Remove the air from the solvent lines
	c. Open venting valve	c. Close the venting valve on the left side of the LDA

Figure 74. Power Entry Module

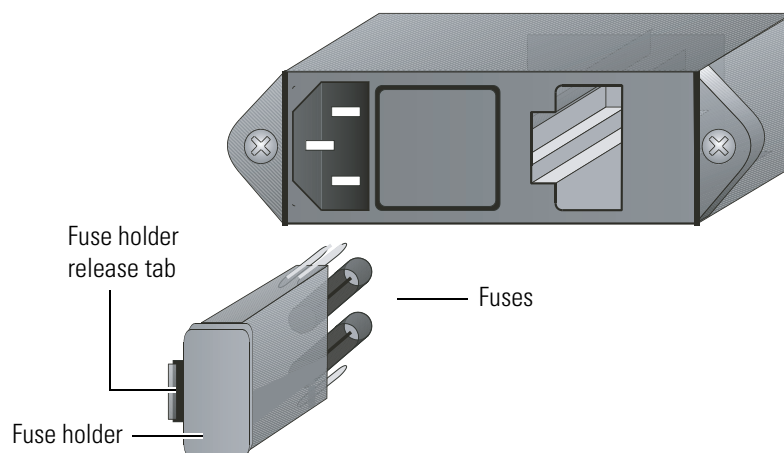

Pump Pulsation

Pump pulsation is the variation in pressure with time due to the motion of the pump pistons.

This section contains the following topics:

- [Normal Pressure Pulsation](#)
- [Abnormal Pressure Pulsation](#)

Normal Pressure Pulsation

The pump continuously monitors the system pressure and bases its pressure readout on a 30 s interval. Under normal operating conditions, the Surveyor MS Pump Plus shows very small variation in pressure. At pressures greater than 100 bar (1450 psi), the pump pulsation should be less than 1%.

The pressure status readback for the MS pump in the Information View is in standard deviation percent. Therefore, at backpressures greater than 100 bar, a value of 1.0 or less is acceptable. See “[Monitoring Pump Pulsation](#)” on [page 29](#) for instructions on monitoring the backpressure of your system from the data system.

Note Because the Surveyor MS Pump Plus does not use electronic damping, its pressure fluctuation often appears to be higher than that for conventional pumps.

Abnormal Pressure Pulsation

Abnormal pressure pulsations can normally be divided into two categories. Large pressure pulsations are generally considered to be those with a standard deviation in pressure of greater than 10 bar (147 psi). Minor pressure pulsations are those with a standard deviation in pressure of less than 10 bar.

Pressure Pulsations with SD over 10 Bar

Pressure pulsations with a standard deviation of the pressure greater than 10 bar are, in most cases, caused by air bubbles trapped in one of the piston chambers. To clear trapped air bubbles, it is recommended that you run the MS pump at about 500 $\mu\text{L}/\text{min}$ with methanol or acetonitrile for about 15 minutes. This flow rate is much more effective than purging at higher flow rates with methanol / buffer mixtures.

Strong pump pulsations can also be caused by insufficient flow to the pump. If the above procedure does not reduce the pulsation, replace the solvent reservoir filters and thoroughly purge air from the system.

If it is determined that the cause is not related to trapped air, the cause might be related to one or more damaged piston seals. Replace both piston seals as described in [Chapter 4](#), “[Maintenance](#).”

If the problem still persists after the seals have been changed, the problem is likely due to a contaminated check valve. For low flow ($< 50 \mu\text{L}/\text{min}$) applications, cleaning a check valve is normally not effective. Most likely one or both check valve assemblies needs to be removed and replaced.

Pressure Pulsations with SD between 3 and 10 Bar

Pressure pulsations with a standard deviation of 3 to 10 bar are of various origins. You can continue working, but you should try to find the reason for the pulsation as soon as possible.

Baseline Noise at Low Pressures (under 40 Bar)

HPLC pumps are optimized to deliver a constant flow with a minimum of pressure fluctuations when they are operated in the range of 40 to 400 bar (580 to 5800 psi). The MS pump provides stable flow over the entire pressure range used by HPLC.

Under extreme conditions (flow rates of less than 100 $\mu\text{L}/\text{min}$) and with a low backpressure (less than 40 bar), you might observe a slight instability in the detector baseline at high sensitivity.

This problem can usually be fixed by adding a flow restrictor to your system between the Surveyor MS Pump Plus and autosampler to increase the backpressure to a level greater than 40 bar.

Some typical applications susceptible to this problem include the following:

- Flow injection analysis (FIA) using an LC/MS performed at 10 to 50 $\mu\text{L}/\text{min}$ without an HPLC column
- Capillary LC at 3 to 5 $\mu\text{L}/\text{min}$ and 15 to 20 bar

UV detector performance is affected at high sensitivity by any variation of backpressure and flow rate. The Surveyor MS Pump Plus should normally be operated with at least 40 bar of backpressure. If necessary, use a flow restrictor to increase the backpressure of your system.

Insufficient Solvent Flow from the Pump Outlet

If there is insufficient flow when the MS pump is running, the problem is usually a result of one of the following:

- [Pump Cavitation](#)
- [Blocked Proportioning Valve](#)
- [Blocked Check Valve](#)

Pump Cavitation

A restriction in flow from the solvent reservoir to the pump can cause the pump to cavitate, which results in erratic mobile phase delivery. In extreme cases, there might be no flow at all. The reason is usually either a blocked solvent reservoir filter or a restricted solvent inlet line. A possible but much less probable cause could be a restriction inside of the vacuum degasser.

If replacing the solvent reservoir filter does not solve the problem, do the following:

1. Disconnect the solvent reservoir A line from the inlet port of the degasser and verify unrestricted flow of solvent through the tubing.
2. If the solvent flow is normal, reconnect the line to the inlet port of the degasser and disconnect the corresponding degasser outlet line.
3. Check for unrestricted flow of solvent through the degassing chamber. The flow out of the degasser is normally slower than that going to the degasser.
4. Repeat the procedure for solvents B, C, and D.

Suspect a problem with the degasser only if there is virtually no flow coming out of the degasser.

Blocked Proportioning Valve

If flow from the degasser is normal, then the next area to check is the proportioning valve.

❖ To check for blockage in a proportioning valve

1. Set the pump to deliver 100% of solvent A at a flow rate of 1000 $\mu\text{L}/\text{min}$.
2. Measure the actual flow rate.
3. Repeat steps 1 and 2 for each channel.

If one or more of the values are low, clean the LDA by flushing it with the appropriate solvents, as described in [“Cleaning the LDA Components without Disassembling the LDA”](#) on [page 38](#).

Occasionally a valve might freeze closed entirely if it hasn't been used for an extended period of time. To open the valve, insert the valve tool (stainless steel wire) into the valve inlet and push the floating piston away from the valve seat, as described in [“Servicing the Proportioning Valves”](#) on [page 64](#).

Blocked Check Valve

Insufficient flow rate can also be a result of a blockage in one or both check valves. In this case, clean the liquid displacement assembly by flushing it with the appropriate solvents, as described in [“Cleaning the LDA Components without Disassembling the LDA”](#) on [page 38](#).

Irreproducible Retention Times

There are many reasons for retention time problems. Some of the more common causes are:

- An old or damaged column
- Inconsistent stationary phase (Was a new column installed?)
- A validated method lacks robustness
- Changes in mobile phase composition
- Temperature fluctuations
- Pump problems

If you suspect the pump to be responsible, replace the column with a flow restrictor and run a step gradient, as described in [“Testing the Pump Proportioning”](#) on [page 31](#).

Inaccuracy in the steps is most likely caused by contamination of the proportioning valves. Clean the LDA by flushing it with the appropriate solvents, as described in [“Cleaning the LDA Components without Disassembling the LDA”](#) on [page 38](#).

Accessories and Replacement Parts

This chapter contains a list of parts that can be replaced by Thermo Fisher Scientific factory-trained personnel. Accompanying the list of parts are the corresponding part numbers by which they can be ordered from your local Thermo Fisher Scientific service representative.

The replaceable parts are divided into the following sections:

- [Liquid Displacement Assembly \(LDA\) Parts](#)
- [MS Pump Accessory Kit](#)
- [Solvent Interconnect Kit](#)
- [Other Parts and Assemblies](#)

Liquid Displacement Assembly (LDA) Parts

The item numbers in [Table 5](#) refer to [Figure 75](#).

Table 5. LDA Parts

Item No.	Qty	Description	Part Number	Material
1	2	Displacement chamber (piston chamber)	00109-03-00001	Ti
2	2	Primary piston seal	00107-18110	PTFE / GFP / Ti
3	2	Seal Ring, Piston Chamber	60053-01020	PTFE
4	2	Piston guide bushing	00201-11330	SS / Ruby
5	2	Secondary piston seal	00107-18114	PE / SS
6	2	Backing ring	00109-03-00002	SS
7	2	Piston unit	00201-11324	Zirconia
8	1	Outlet cartridge film seal	00107-18112	PEEK
9	1	Outlet cartridge	00109-03-00003	SS
10	5	Film sealing, Face, MS Pump, LDA	00950-01-10013	PEEK
11	2	Check valve cartridge	00110-05110	Ti / Ruby
12	2	Retaining clip	00201-11328	SS
13	4	Proportioning valve	00110--01-00007	Ti / Ruby / Sapphire / Zirconia
14	4	Coil unit for proportioning valve	00201-11344	SS / PEEK
15	4	Sealing ring, proportioning valve	00201-11320	PTFE
Set D	1	Pressure sensor set	00201-11338	PEEK / Ti
	4	Nylon screw, coil	00109-04-00005	Nylon

Figure 75. Liquid displacement assembly

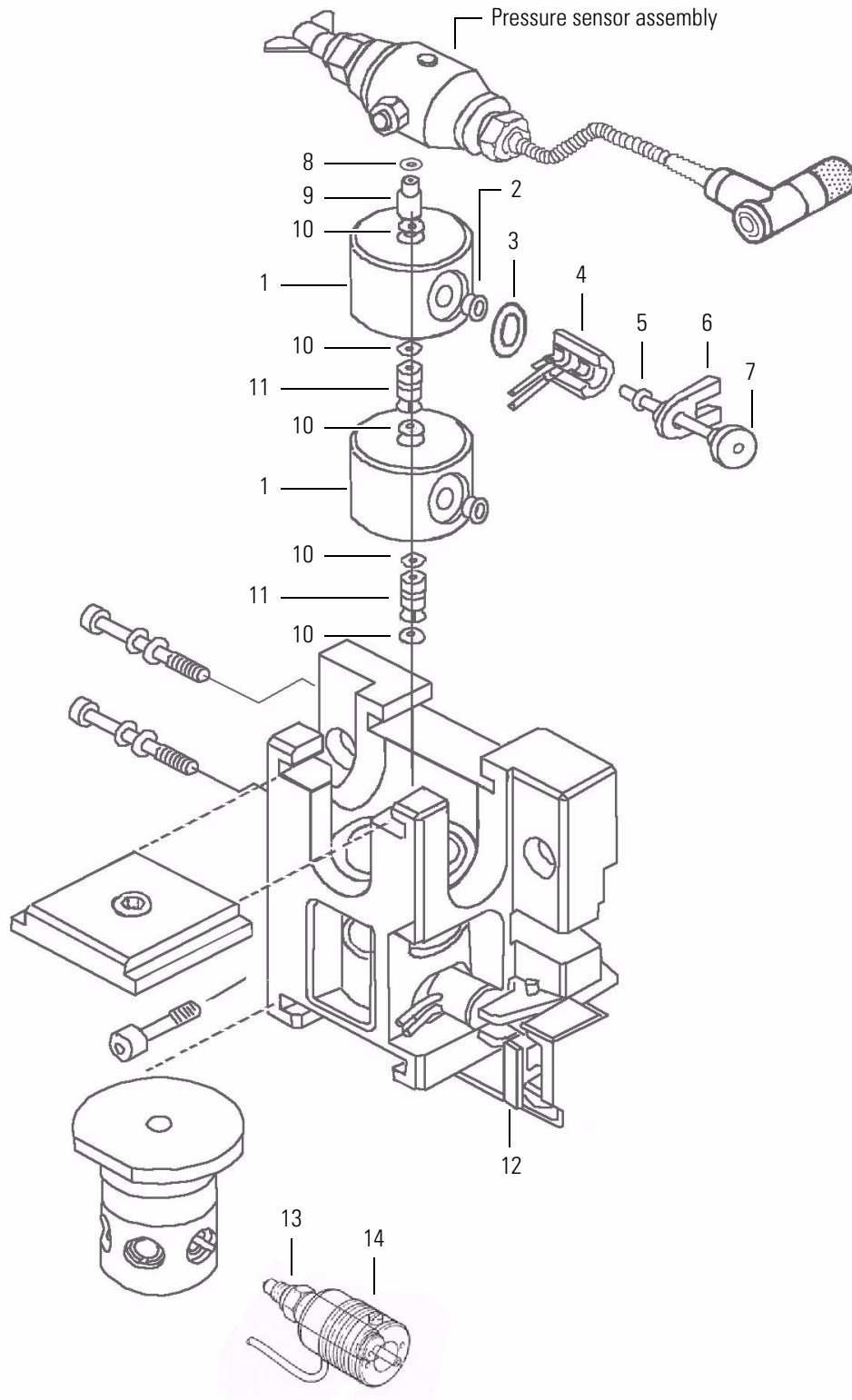

MS Pump Accessory Kit

The following items are contained in the MS pump accessory kit (P/N 72011-62001).

Cable, assembly, RS232, shielded, external PC	72011-63008
Connector, plug, 8 pin, 3.81 mm pitch, Minicombicon	00004-02511
Fitting nut / ferrule, Finger-Tight, 1/16 in. OD tube	00101-18088
Fuse, 2 A Slo-Blo (5 × 20 mm) (2 each)	5120-0025
Luer-type adaptor	A0796-010
Screwdriver, ball driver, hex, 4 mm	00725-00032
Seal removal tool, P1-4	A3216-010
Seal, H/P, Surveyor MS Pump (2 each)	00107-18110
Syringe, Luer-Lok®, 10 mL	3301-0151
Tool, Prop Valve, MS Pump	60053-01017
Tubing, convoluted, pump waste.	F5034-040
Wrench 1/4 in. and 5/16 in.	5401-0400
Wrench, L-hex, 4 mm	00725-00034

Solvent Interconnect Kit

The following items are included in the LC/MS system solvent interconnect kit.

Bottle cap solvent bottles.	A0343-010
Solvent bottle cap adaptor	A3191-010
Solvent filter, 10 micron Teflon.	A4258-010
Tubing, 1/8 in. OD, 240-in length	3219-2004
Fitting, Super Flangeless, 1/8 in. tube, PEEK	00101-18225
Ferrule, Super Flangeless, 1/8 in. tube, PEEK	00101-18017
Label set solvent bottles.	A4158-020
Marker LTR “A”- clip on.	608250001
Marker LTR “B”- clip on.	608250002
Marker LTR “C”- clip on	608250003
Marker LTR “D”- clip on	608250004

Other Parts and Assemblies

The following items include miscellaneous parts and assemblies.

Power cord (European)	6003-0330
Power cord (U.S.A.)	6003-0160
Pulse dampening assembly	00201-11340
RS232 cable	72011-63008
Solvent inlet and outlet line tubing (order by length)	3219-2004
Solvent reservoir filter	A4258-010
Vacuum degas assembly.	00108-00454
Kit, Seal, Surveyor MS Pump	60052-62012
Right door assembly, Surveyor MS Pump Plus	60053-60067
Chassis, Surveyor MS Pump	72011-10001
Front panel, Surveyor MS Pump	72011-10002
PCB assembly, degas monitor and serial	72011-61001
Cable assembly, DI/O to main PCB	72011-63001
Cable assembly, serial to main PCB.	72011-63002
Cable assembly, Degas PCB to main PCB	72011-63003
Cable assembly, DC supply to main PCB	72011-63004
Cable assembly, AC power to Rheos and supply	72011-63005
Cable, motor index	00950-01-00001
Kit, maintenance, Surveyor MS Pump	60052-62010

Index

Numerics

- 5-connector interconnect cable
 - connections 13
 - figure 12
- 7-connector interconnect cable
 - connections 14
 - figure 14

A

- accessories
 - PEEK fittings 19
 - replacement parts 77
 - stainless steel tubing 5, 19
- accessory kit, contents 10
- adapter cables
 - for the MS pump and the 7-connector interconnect cable (figure) 14
- air bubbles
 - effect on pump pulsation 30, 73
 - effect on retention time reproducibility 69
 - removing 73
 - removing from the piston chambers 37
- autosampler
 - configuring the input signal polarities 23
 - connecting to pump 19

B

- back panel
 - clearance requirements 11
 - connections 11
- backing rings, orientation 57
- backpressure, normal operating 74
- baseline noise, caused by vacuum pump cycling 3
- buffered solutions, pumping 36

C

- cables
 - interconnect 12
 - packing location 12
 - power 10
 - RS232 serial communication 2, 12
- capillary LC 74
- captive screws, location 42
- channel, degasser volume 3
- check valves
 - blocked 75
 - cleaning 38, 48
 - contamination 30, 71
 - damaging 47
 - description 3
 - flow direction 53
 - installing 53
 - replacement part 78
 - replacing 47
 - seal rings 48
- checklist 10
- cleaning
 - components of liquid displacement assembly 47
 - pistons 48
- column
 - blockage 68
 - not equilibrated 68, 69
- compression lid
 - installing 56
 - removing 43
- compression tool 18
- configuring the signal polarities for the autosampler 23
- connections
 - autosampler 20
 - back panel 11
 - pulse dampener 20
 - solvent lines 15
 - system synchronization cable 12
- creep caused by salt buildup 36

crossover tube
function 3
removing 40

D

DB-9 pin connector 12
degasser
description 3
specifications 7
delay volume
determining 33
pulse dampener 2
pump 2, 3, 5
specification 7
detector
baseline instability 74
performance 74
dwell volume
See delay volume

E

electromagnet compatibility iv
electronic pulse damping 29

F

FCC compliance iv
fittings
connection to autosampler 19
Super Flangeless 17
flow direction, of check valves 53
flow injection analysis 74
flow rate
low 74
minimum and maximum 7
flow restrictor
used to increase backpressure 74
using to increase backpressure 31
fuse
blown 70
power entry module 70

G

gradient delay volume
See delay volume

H

holding hooks 58

I

installation
accessory kit 10
checklist 10
serial communication cable 12
unpacking 10
interconnect cable 12

L

LEDs, front panel 6
Liquid Displacement Assembly (LDA)
cleaning 47, 75
components 3, 39
compression plate 43
detaching from pump 42
disassembling 49
loosening setscrews 43
schematic diagram 51
low back pressure 74
low flow rates 74

M

maintenance, records 9
manual bleeder valve 27

O

outlet cartridge, installing 55

P

peak area, reproducibility 69
peak shape, effect of plumbing 69
PEEK fittings 10, 19
piston bore 54
piston chambers
installing 55
removing 46
piston guide bushings
flushing 36
installing 57
replacement part 78
pistons
cause of scratches 36
cleaning 48
movement 59
removing 44
replacement part 78
retaining clips 63
salt buildup 36
stroke volume 7

- platform, solvent 17
- plunger seals, leaking 71
- power entry module, attaching power cord 21
- power requirements 7
- pressure
 - operating range 7
 - resolution 7
 - settings range 7
 - transducer 3
- pressure readback 30
- pressure sensor assembly
 - installing 55
 - removing 44
 - replacement part 78
- pressure sensor cable
 - connecting 63
 - disconnecting 40
- primary piston seals
 - orientation of spring 50
 - seating 50
- priming the pulse dampener 27
- proportioning accuracy
 - test failure 33
 - testing 31
- proportioning valves
 - blocked 75
 - cleaning 38
 - components 64
 - connecting wires 42
 - contamination 30, 71, 76
 - freezing 64
 - opening 64
 - problems 71
 - replacement part 78
- pulsation test
 - failure 33
 - monitoring backpressure 29
- pulse dampener
 - description 5
 - outlet 27
- pump
 - cable disconnected 70
 - cavitation 75
 - components 2
 - delay volume 3, 5
 - environmental requirements 11
 - leaks 69
 - motor will not run 70
 - powering on 21
 - specifications 7
- pump program, downloading 6

- pump pulsation
 - abnormal 73
 - causes of excessive 30
 - damaged piston seals 73
 - defined 72
 - dirty check valves 73
 - dirty solvent reservoir filters 73
 - effect of trapped air 30
 - monitoring 29
 - normal 73

Q

- quaternary, functional description of pump 2

R

- rear panel connections
 - See* back panel
- records, maintenance 9
- regulatory compliance iii
- retaining clips
 - figure 63
 - installing 63
- retention time, problems 76
- RS232 serial communication cable 12

S

- safety standards iii
- salt buildup
 - cause 36
 - preventing 36
- schematic diagram of the LDA 51
- seal installation tool 50
- seal removal tool 48
- seal rings
 - removing 48
 - reusing 49
- seals
 - orientation of primary piston seal 50
 - plunger 71
 - pushing into the piston chamber 50
 - replacement part 78
 - replacing 33, 49
 - ruining 49
 - soaking in methanol 49
- secondary piston seal, replacement part 78
- serial communication
 - configuring the COM port 21
 - connecting the cable 12
- shipping container, contents 10
- signal polarity settings for the autosampler 23

Index: T

- sinker frit 65
- solvent
 - outlet tubing 19
 - platform 17
- solvent interconnect kit parts 80
- solvent lines
 - connecting 15
 - non-metallic filters 16
 - replacement part 81
- solvent reservoir filter
 - clogged 65
 - replacement part 81
 - replacing 65, 73
- solvents
 - erratic flow 75
 - filtering 15
 - no flow 75
- specifications, pump 7
- status
 - LEDs 2, 6
 - Status page of the Information view 29
- steel compression ring 18
- step-gradient for testing proportioning accuracy 76
- Super Flangeless fittings 17

T

- tools
 - 4 mm balldriver wrench 40
 - 4 mm Hex wrench 10, 40
 - Allen wrench 10
 - seal installation 50
 - seal removal tool 48
- troubleshooting
 - high backpressure 68
 - no flow 68
 - no instrument control 69
 - no peaks 68
 - poor peak shape 69
 - retention time reproducibility 69
 - tips 67
 - unstable baseline 68
- Troubleshooting Guide 70

U

- unpacking your pump 10

V

- vacuum degasser
 - description 3
 - specifications 7

- valves
 - check
 - See check valves
 - manual bleeder 27
 - proportioning
 - See proportioning valves

X

- Xcalibur
 - configuring the Surveyor Autosampler 23
 - Direct Control dialog box 25
 - Status page of the Information view 30