



# EVOM & EVOMX

*Epithelial Voltohmmeters*

## **INSTRUCTION MANUAL**

Serial No. \_\_\_\_\_

021308

[www.wpiinc.com](http://www.wpiinc.com)

**World Precision Instruments**



# CONTENTS

INTRODUCTION.....	1
INSTRUMENT DESCRIPTION .....	2
Parts List .....	2
Unpacking.....	2
Set-up.....	2
Features and Controls.....	3
Instrument Self-tests .....	5
OPERATING INSTRUCTIONS .....	7
1. Connecting the electrode to the meter .....	7
2. STX2 electrode preparation.....	7
3. Placement of the electrode in the sample cup .....	7
4. Measuring Resistance .....	9
5. Measuring Voltage.....	10
INSTRUMENT MAINTENANCE.....	10
Electrodes.....	10
EVOM Meter.....	12
ACCESSORIES.....	13
TROUBLESHOOTING.....	15
SPECIFICATIONS.....	19
APPENDIX A: SUMMARY OF OPERATING INSTRUCTIONS.....	20
APPENDIX B: IMPORTANT APPLICATION NOTES.....	21
Resistance value of the “blank” insert.....	21
Special Note: 24 mm diameter (6-well) inserts and STX electrodes .....	21
Improving the Accuracy and Repeatability of the System.....	22
APPENDIX C: RESISTANCE CALCULATIONS.....	23
Resistance.....	23
Unit Area Resistance .....	23
WARRANTY .....	25
Claims and Returns .....	25
Repairs .....	25
DECLARATION OF CONFORMITY.....	26



## **INTRODUCTION**

**EVOM** was the first instrument designed to perform routine TEER (Trans Epithelial Electrical Resistance) in tissue culture research. The confluence of the cellular monolayer is determined by a sharp increase in TEER detected using the unique electronic circuit of the **EVOM** and **STX2** electrode (included with the instrument). The **EVOM** qualitatively measures cell monolayer health and quantitatively measures cell confluence. When combined with WPI's **EndOhm** chamber, the **EVOM** can also be used to perform trans *endothelial* electrical resistance measurement.

The battery-powered **EVOM** produces an AC current that avoids electrode metal deposits and adverse effects on tissues, which can otherwise be caused by a DC current. In addition, resistance readings are unaffected by membrane capacitance and membrane voltage.

A modified **version of the EVOM**, the **EVOMX**, has been adapted for multi-well testing by replacing the momentary R (resistance) measurement pushbutton with a toggle switch, allowing constant monitoring of resistance. The **EVOMX** also has a BNC connector for data output to a chart recorder.

**NOTE:** If the **EVOM** system is to be used *for resistance measurement only*, sections in this manual pertaining to use of the electrode for voltage measurement can be disregarded. For resistance measurement, the electrode does not need to be equilibrated or preconditioned before use.

---

# INSTRUMENT DESCRIPTION

## Parts List

- EVOM** or **EVOMX** meter (batteries installed: one 9V alkaline battery, six 1.5V alkaline AA batteries)
- STX2** electrode set
- 600-grade ultra-fine sandpaper
- This **Instruction Manual**

## Unpacking

Upon receipt of this instrument, make a thorough inspection of the contents and check for possible damage. Missing cartons or obvious damage to cartons should be noted on the delivery receipt before signing. Concealed loss or damage should be reported at once to the carrier and an inspection requested. Please read the section entitled “Claims and Returns” on the Warranty page of this manual. Please call WPI Customer Service if any parts are missing.

**Returns:** Do not return any goods to WPI without obtaining prior approval (RMA # required) and instructions from our returns Department. Goods returned (unauthorized) by collect freight may be refused. If a return shipment is necessary, use the original container. If the original container is not available, use a suitable substitute that is rigid and of adequate size. Wrap the instrument in paper or plastic surrounded with at least 100 mm (four inches) of shock absorbing material. Please read the section entitled “Claims and Returns” on the Warranty page of this manual.

## Set-up

Required but not provided: small flat-head screwdriver to fit zero-adjustment screws.

### Meter

- The **EVOM** / **EVOMX** meter is shipped with batteries installed. It is ready for use.

### Electrode

- For resistance measurements only, the **STX2** electrode can be used directly from dry storage without preconditioning.
- For voltage measurements, the electrode needs to be equilibrated. See Electrode Preparation under OPERATING INSTRUCTIONS

**Features and Controls**

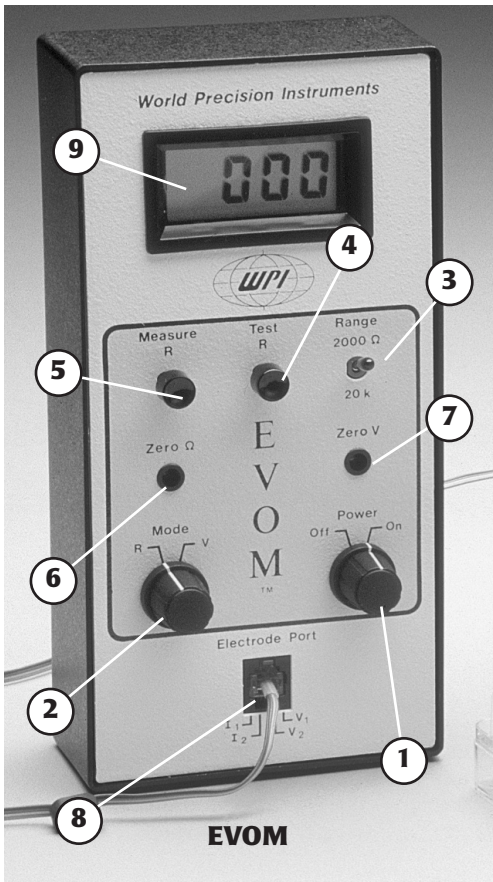

① **Power Switch On/Off:** turns the meter on and off.

② **Mode Switch R/V:** When in the R position, the meter is in the resistance-measuring mode. When in the V position, the meter is in the voltage-measuring mode.

③ **Range Toggle Switch 2000Ω/20K:** This switch only functions when the meter is in R mode. At the 2000Ω position, the full scale is 2000Ω. At the 20K position, the full scale is 20 KΩ.

④ **Test R Pushbutton:** Pressing this pushbutton when the meter is in the R mode will connect the circuit to an internal 1000Ω standard resistor whose resistance will then be measured. If the display shows a value close to 1000Ω ( $\pm 1\%$ ), then the meter’s resistance measurement function is performing acceptably. During the test, the external electrode is disconnected from the meter by the switch. Therefore, the electrode does not need to be connected to

the meter during the test. In model **EVOMX**, the Measure R pushbutton (see below) has been replaced by a toggle switch. The toggle switch must be in the off position when this test is performed.

⑤ **Measure R Pushbutton (EVOM):** When the meter is in the R mode, pressing this button causes the resistance across the two electrode probes to be measured. The resistance measuring circuit will function only when this switch is depressed; it will shut off when the switch is released. **Do not press this button without the electrode immersed in solution, otherwise the circuit will overload and a warning tone will sound.**

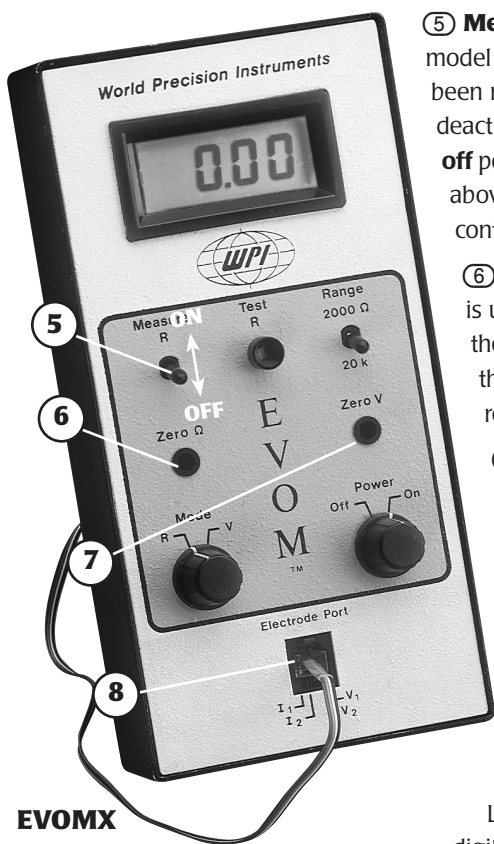

## EVOMX

the meter is measuring voltage, it displays the potential difference between the two electrodes in millivolts (mV) up to 199.9 mV. When the meter is measuring resistance, it displays the resistance between the two electrode probes in  $\Omega$  (with range switch set to 2000  $\Omega$ ) or K $\Omega$  (with range switch set to 20 K). When a reading is off scale (high), a single digit "1" will appear at the furthestmost left position, reflecting an off-scale reading.

**(10) STX2 Electrode:** The **STX2** electrode incorporates a fixed pair of probes, 4 mm wide and 1 mm in thickness. Each probe has an outer and an inner electrode (see Fig. 1). The outside electrodes are small silver (Ag) pads that pass current through the membrane sample. They are referred to as current electrodes and are connected to the  $I_1$  and  $I_2$  pins of the telephone-type

**(5) Measure R Toggle Switch (EVOMX):** In model **EVOMX**, the Measure R pushbutton has been replaced by a toggle switch and the alarm deactivated. The toggle switch must be in the **off** position (down) when performing the test above. In the up position, the switch is **on** for continuous resistance measurement.

**(6) ZERO  $\Omega$  adjustment screw:** This screw is used to zero the meter display while in the R mode. The ZERO  $\Omega$  adjustment affects the meter display only. It does not offset residual resistance of the fluid or electrode

**(7) ZERO V adjustment screw:** This screw is used to adjust the zero in V mode. It should not be adjusted until the electrode has been preconditioned.

**(8) Electrode port:** Insertion of the telephone-type Plug connector of the **STX2** electrode to this port connects the electrode to the meter.

**(9) Digital LCD Display:** The Digital LCD Display registers readings up to 4 digits, depending on the scale used. When





plug connector. The inner electrodes are small Ag/AgCl pellet voltage sensors. They are referred to as voltage electrodes and are connected to the  $V_1$  and  $V_2$  pins of the telephone-type plug connector.

## Instrument Self-tests

It is recommended that **EVOM** be put through the three self-tests described below before using it for the first time and then periodically thereafter. When there is a concern that the meter or the electrode is not functioning properly, the following three testing protocols may be used to confirm **EVOM**'s operating status.

### TESTING THE METER

This procedure tests the both the voltage function circuitry as well as that of the resistance.

1. Turn the Mode Switch to R.
2. Turn the Power Switch on.
3. Press the TEST R button

**NOTE:** Do not press the TEST button when taking measurements or you may obtain a false resistance measurement.

The meter should read as follows:

Range Switch Position	Display Reading
2000 $\Omega$	1000 $\Omega \pm 10 \Omega (\pm 1\%)$
20 K $\Omega$	1 k $\Omega$

If the meter does not show these values, consult the "Troubleshooting" section in this manual.

### TESTING THE ELECTRODE FOR RESISTANCE MEASUREMENTS

1. Insert the telephone-type plug at the end of the flexible electrode cable into the Electrode Port on the meter.
2. Immerse the electrode tips in a vessel containing an electrolyte solution similar to the experimental culture medium or in 0.1-0.15 M potassium chloride (KCl) or sodium chloride (NaCl). *Do not use a culture insert.*
3. Turn the Mode Switch to "R"
4. Turn the Power on.
5. When the meter is in the R mode and neither the Test R nor Measure R switch is

---

pressed, the meter should display zero or very close to zero. If not, adjust the “Zero  $\Omega$ ” screw with a small flat-head screwdriver until the meter shows a reading of 0.

**NOTE:** Do not press either the Test R switch or the Measure R switch while adjusting the zero. The ZERO  $\Omega$  adjustment affects the meter display only. It does not offset residual resistance of the fluid or electrode. Therefore, the zero can also be adjusted without the electrode connected to the meter.

**6.** Press the “Measure R” with the electrode still immersed in the electrolyte solution. The reading should be less than 200  $\Omega$  and stable if the electrode is kept stationary. If it is not, investigate the following as likely causes:

- Dirty or contaminated electrodes – see Cleaning Procedures
- Culture media or electrolyte solution contamination or concentration error
- Instrument battery failure

## **TESTING THE ELECTRODE FOR VOLTAGE MEASUREMENTS**

**1.** Equilibrate the electrode as instructed in the “Electrode Preparation” section under OPERATING INSTRUCTIONS.

**2.** Immerse the electrode tips in an electrolyte solution similar to the experimental culture medium or in 0.1-0.15 M KCl or NaCl.

**3.** Turn the Mode Switch to “V”

**4.** Turn the Power on.

**5.** The digital panel meter may read 5 or 10 mV due to the asymmetry of the voltage electrode pair. After 15 minutes, adjust the “Zero V” screw with a flat-head screwdriver until the meter shows a reading of 0.0 mV. If the electrode asymmetry potential difference exceeds the zero adjustment range ( $\pm 15\text{mV}$ ), the central electrodes may be dirty or contaminated. See the “Cleaning the Electrode” Section under INSTRUMENT MAINTENANCE.

**6.** Voltage drift will only be detected if several measurements are made over a period of time.

**7.** If the meter reads zero, testing is complete. If the meter still does not read zero, see “Troubleshooting”.

# OPERATING INSTRUCTIONS

## 1. Connecting the electrode to the meter

Insert the telephone-type plug at the end of the flexible electrode cable into the electrode port on the meter.

## 2. STX2 electrode preparation

- For *resistance* measurement, the electrode can be used directly out of dry storage without any preconditioning.
- For *voltage* measurements, the electrodes need to be equilibrated to eliminate any offset before use. Electrochemists have long used the following equilibration technique to assure voltage stability and a low inter-electrode potential difference:
  - The **STX2** voltage electrode pairs are shorted together internally when they are connected to the instrument and the instrument power switch is off. The user may therefore immerse the electrode in electrolyte solution (e.g., 0.1 – 0.15 M KCl) with the electrodes connected to the **EVOM** (power off) to allow the probes to equilibrate. With the voltage electrode connector pins thus short-circuited for several hours, the asymmetrical potential difference across the two voltage electrodes is reduced. The inter-electrode DC potential will be a few millivolts or less and quite stable. Table 1 lists the recommended equilibration time before using the electrode.
- Sterilize the electrodes, if desired. See section on Sterilization under Instrument Maintenance.

**Table 1: STX2 Electrode Equilibration Time**

Electrode Condition	Equilibration Time
Never tested for voltage drift	24 hours
Stored dry	24 hours
Stored in solution	2 hours

## 3. Placement of the electrode in the sample cup

The **STX2** electrode is designed to facilitate measurements of membrane voltage and resistance of cultured epithelia in tissue culture wells. The lengths of the electrodes are unequal allowing the longer (external) electrode to touch the bottom of the dish containing the external culture media while preventing the shorter (internal electrode) from reaching the bottom of the tissue culture cup or insert (see Fig. 1). This feature ensures proper positioning between the electrode and the cell layer in the cup during the trans membrane measurement. In addition, by positioning the longer tip so that

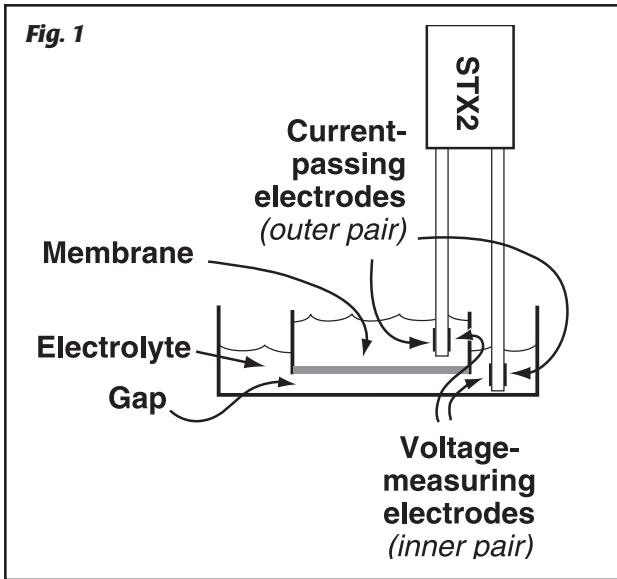

it touches the bottom of the dish each time, the reproducibility of the measurements is significantly improved. Even small differences in the apparent fluid resistance may occur if the depth to which the electrode tips are immersed varies.

Place the electrode into the well so the tips just touch the bottom of the wells *without flexing* the electrode. To obtain reproducible results in the same cup, the position

of the electrodes must remain constant. To improve the reproducibility and stability of the measurement, it is important to steady the electrode while measuring.

When moving the electrodes from one sample cup to another, it is best not to rinse the electrodes with distilled water. Silver/silver chloride electrodes may take several minutes to recover from exposure to distilled water, during which time the potential may drift by a few millivolts. If it is necessary to wash the electrodes between measurements to avoid carryover of one sample into the next, the electrodes should be rinsed with the experimental culture media.

**NOTE:** Transwell inserts made by Corning Costar, in general, have a greater distance between the bottom of the filter cup and the bottom of the plate (see Fig. 1). This gap also varies from one lot to the other. It may be large enough to cause the shorter internal electrode to hit the cell layer when the longer electrode touches the bottom of the dish. In this case, the Transwell user can sand *0.5 mm* off the shorter probe. **CAUTION:** Only the plastic part of the tip can be sanded. Do not sand any metal part of the tip or damage to the electrode will result.

Alternatively, the optional **STX3** electrodes, which are adjustable, can be used instead of the **STX2**.

#### 4. Measuring Resistance

Set the Mode Switch to R.

Turn the meter power on.

Add electrolyte to a blank cup, *i.e.*, the cell culture insert without cells.

Insert the electrode into the blank cup.

Push the Measure R button. A steady ohms reading of the solution resistance should result. The value of the blank always adds to the total resistance measured across a tissue culture membrane. See Appendix A for a more detailed discussion of the source of the blank resistance.

##### **Blank Resistance:**

*The blank resistance must be measured and then subtracted from the resistance reading across tissue in order to obtain the true tissue resistance. See Appendix C for resistance calculations and examples.*

##### **Unit Area Resistance:**

As the resistance is inversely proportional to the area of the tissue, instead of reporting resistance, typically the product of the resistance and the area is calculated and reported. This value is independent of the area of the membrane used.

**NOTE:** Resistance readings for 24 mm or larger diameter inserts obtained using the **EVOM** with the **STX2** electrode should not be converted to unit area resistance. See additional discussion of this point in APPENDIX B “Special Note: 24 mm diameter (6-well) inserts and the STX electrodes”.

The **unit area resistance** is obtained by **multiplying** the meter readings by the effective surface area of the filter membrane. The dimension is  $\Omega \text{ cm}^2$ . This is because the resistance is *inversely* proportional to the surface area. Thus, the larger the membrane, the lower the resistance.

$$\text{Resistance of a unit area} = \text{Resistance } (\Omega) \times \text{Effective Membrane Area}^* (\text{cm}^2)$$

\* See manufacturing specifications for the particular insert

$$\text{Unit Area} = 1 \text{ cm}^2$$

**The unit area resistance is independent of the area of the membrane used and may be used to compare data obtained from inserts of different sizes.**

---

## 5. Measuring Voltage

Set the Mode Switch to V.

Turn the Meter power on.

Insert an equilibrated electrode into the cell culture insert. A steady voltage reading of the trans membrane potential should result. Note that the shorter (internal) electrode is connected to instrument ground and acts as the reference electrode. If the meter reading is positive in voltage mode, it means that the basal side of the cellular tissue (the side adhering to the filter of the insert) is positive with respect to apical side (exposed). Conversely, if the meter is reading negative, it means that the basal side is negative with respect to the apical side.

*See Appendix A for a summary of the operating instructions.*

## INSTRUMENT MAINTENANCE

---

### Replacement Parts

---

WPI Part #	Description
STX2	Replacement Electrode Set
2101	One standard 9V battery (ANSI 1604A)
3569	Six standard 1.5V AA batteries (ANSI - 15A)

---

## Electrodes

**Caution:** Do not flame electrodes. Doing so will cause them to melt and invalidate any warranty.

### Cleaning the STX2 Electrode

With use, the electrode surface can become coated with foreign materials. This build-up, or contamination, will degrade the performance of the system resulting in slow or drifting voltage readings (resistance readings will probably not be affected).

We recommend three steps to clean the electrode:

1. Using a cotton swab soaked with alcohol, lightly rub the surface of the electrode.
2. If there is no improvement after following step 1 above, then soak the electrode in undiluted household bleach solution for 3 minutes. Rinse with water immediately after soaking. *Ensure that only the electrode tip is exposed to bleach.* Do not permit the bleach to touch the upper part of the electrode. If additional cleaning is required, go to Step 3.

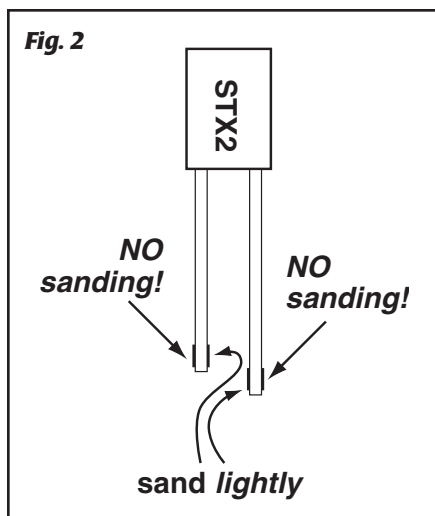

**3.** Lightly rub the voltage electrode (silver pellet on the inner surface near the electrode tips) of the **STX2** with the 600-grade Ultra Fine sandpaper provided (see Fig. 2). Only a very thin surface layer of the pellet should be removed. Repeated rubbing will eventually remove the Ag/AgCl pellets. When rubbing no longer improves the voltage readings, the electrode should be replaced. In the absence of 600-grade sandpaper, an ink eraser may be substituted to clean the electrodes.

### **Sterilizing the STX2 Electrode**

The **STX2** electrodes are non-sterile as supplied. They may be sterilized using

alcohol (one of the most common methods), ethylene oxide, UV, or a bactericide, *e.g.*, Cidex Plus (WPI #7364) or Sporicidin.

**NOTE:** The electrode cannot be sterilized by autoclaving

### **A Typical Sterilization Protocol Using Alcohol**

Do not leave the electrode in alcohol for more than 30 minutes each time. Continuously soaking the electrode in alcohol will weaken the protective coating on the electrode and shorten its lifetime.

In a laminar flow hood:

- 1.** Immerse the electrodes in 70% ethanol for 15 minutes. Allow them to air dry for 15 seconds.
- 2.** Rinse the electrode in a sterile electrolyte solution similar to the experimental cell culture medium or in 0.1 – 0.15 M KCl or NaCl.
- 3.** For *resistance* measurements, the electrode is now ready to use.
- 4.** For *voltage* measurements, allow the electrode to equilibrate in the sterile electrolyte for 15 minutes. Then, adjust the “voltage zero” on the **EVOM** to balance any residual offset between the two probes.

The electrode can be left in a UV hood to keep it sterile.

**NOTE:** When the electrode is exposed to strong visible or UV light, a dark colored oxide film will slowly form on the electrode surface. This film normally will not affect the

---

performance of the electrode. To avoid the formation of the film, shield the electrode from strong light.

### **Storage of the Electrode**

*Short term storage (less than a week or two):* Immerse the electrode tip in electrolyte solution. Make sure the electrode cable plug is connected to the electrode port on the **EVOM** meter so that the system is internally short-circuited and electrode symmetry is maintained.

*Long term storage (greater than a week or two):* When storing for long periods of time, the electrode should be rinsed with distilled water and stored dry and in the dark.

## **EVOM Meter**

Battery Replacement:

**EVOM** has two independent sets of batteries:

- One set contains six AA alkaline batteries that power most of the electric circuit, including the display. When this set of batteries is low, the “LO BAT” will appear on the digital meter. Therefore, this set of batteries does not need to be changed until the display indicates.
- The second set of batteries contains only one 9-volt alkaline battery that is used to power the electric current injecting circuit. There is no low battery indicator for this battery. Therefore, this battery should be checked or replaced every six months.

To replace the batteries, remove the screws on the bottom of the instrument case and withdraw the front panel assembly from the case. Observe the polarity markings and replace battery cells accordingly. Reinsert the instrument into case and secure it. Check the R Zero and adjust, if necessary, with the **EVOM** in the R Mode.

To conserve battery life, turn off the instrument when not in use.



## ACCESSORIES

**WPI Part #                      Item**

### METER ACCESSORIES

**3993**                      Electrode Adapter (for electrodes with 2mm pins)  
**2851**                      BNC cable, 6-ft

### ELECTRODES FOR TEER (EPITHELIAL) MEASUREMENT

**STX2**                      Replacement Electrode Set  
**STX3**                      Adjustable Electrode Set

### ELECTRODES FOR ENDOTHELIAL/EPITHELIAL MEASUREMENT

**ENDOHM-6**                      Endohm for 6 mm culture cup (24 wells per plate) and the 12 mm  
 Millicell-CM  
**ENDOHM-12**                      Endohm for 12 mm culture cup (12 wells per plate)  
**ENDOHM-24SNAP**                      Endohm for 24 mm and Costar Snapwell' cup (6 wells per plate)

### ELECTRODES FOR HTS (High-Throughput) ENDOTHELIAL MEASUREMENT

**STX100C**                      STX100 for Corning Costar HTS Transwell-24  
**STX100F**                      STX100 for Falcon HTS Multi-well testing  
**STX100M**                      STX100 for Millipore Multiscreen CaCo 96-Well Plate  
**STX100F96**                      STX100 for BD Falcon HTS 96 Multiwell Plate  
**STX100C96**                      STX100 for Corning HTS 96-Well Plate

### CELL CULTURE CUPS WITH SYNTHETIC MEMBRANES

**CALICELL-12**                      12 mm Calibration Cell for Endohm-6 and Endohm-12  
**CALICELL-24**                      24 mm Calibration Cell for Endohm-24

### OTHER

**7364**                      Cidex Plus (quart)  
**LAB-TRAX-4**                      4-Channel Data Acquisition System

**Electrode Adapter** (WPI# **3993**) converts the four contacts in the phone plug into four independent 2-mm jack. It allows the user to utilize the **EVOM** meter with an Ussing system or other four-electrode system.

**STX2** electrode can be used with both the **EVOM** and the **EVOMX** and is designed to facilitate measurements of membrane voltage and resistance (TEER) of cultured epithelia directly in tissue culture wells . The electrode incorporates a fixed pair of probes, 4 mm wide and 1 mm in thickness. Each probe has an outer (voltage) and an inner (current) electrode

**STX3** is an alternative electrode to the **STX2** that can be used with both the **EVOM** and

---

the **EVOMX**. It differs from the **STX2** in that the distance between the probes of the **STX3** can be adjusted.

**STX100C** and **STX100F** are optional electrodes specifically for use with the **EVOMX**, but may also be used with the EVOM. Specialized for high throughput screening (HTS) plates, they combine the advantages of the **STX2** and **Endohm**, measuring TEER directly in the culture plate with good reproducibility.

**Endohm** is an optional electrode chamber for the **EVOM** for measuring low-resistance tissue culture cells or when increased precision is desired. It can also be used for studying the tight junction changes induced by chemicals and other factors. Concentric pairs of electrodes above and below the insert membrane results in excellent stability and reproducibility (see Appendix A: Improving the Accuracy and Repeatability of the System). Unlike the **STX2**, the inserts have to be transferred from the culture plate to the **Endohm** chamber to make a measurement.

**CaliCell™** is a cell culture insert with a synthetic membrane which mimics a confluent epithelial membrane's resistance in fluid. Each **CaliCell** insert is has an established resistance measurement determined at the time of manufacture and against which the system resistance can be compared. Used as a control to check the functionality of the system, **CaliCell** is especially useful when working with confluent cells that yield low resistance readings, causing concern that the **EVOM** system is not working. The high resistance readings obtained with **CaliCell** provide reassurance that the **EVOM** system is operational. Although the resistance may vary with time, **CaliCell** cups will remain reasonably constant for several years if stored at room temperature. They can be used to test the **EVOM** (and Ussing) system with a variety of electrode configurations.

# TROUBLESHOOTING

## EVOM Meter

Experience demonstrates that more than 90% of the time, system problems are related to the electrode not the meter itself. Of those failures due to the meter itself, at least half of them are a result of a failed switch due to the presence of corrosion. The typical cause of this corrosion is accidental spillage of saline solution or culture media on the meter. If the meter has been kept free of salt solutions, the batteries are fresh and functional testing of the meter demonstrates acceptable performance results (see the INSTRUMENT SELF-TEST section of this manual), then the meter is working correctly.

## STX2 Electrode

- Although the **STX2** electrode has a warranty of 30 days, its useful lifetime is typically 1 to 2 years, depending on usage.
- When the electrodes fail, the most common symptom is an unstable or unusually high reading. If the current electrode fails, the meter will emit a warning beep.
- When the meter displays a lower than expected resistance, but is stable and reproducible, the most likely cause is related to the cell culture, not the electrode or meter.
- *In situ* tests — There is no quantitative method available to do an *in situ* or wet test on the electrode. However, two qualitative methods may assist the user in determining that the electrode is working and will respond to an increase in resistance:
  1. Use WPI's **CaliCell** to test the electrode. **CaliCell** is a cell culture insert with a synthetic membrane that mimics a confluent epithelial membrane's resistance in fluid. Each **CaliCell** insert is supplied with an established resistance measurement determined at the time of manufacture and against which the system resistance can be compared.
  2. Test the resistance differences between a well filled with electrolyte and a blank culture insert filled with electrolyte. The resistance of electrolyte alone should be less than 50 ohm and stable, if the electrode is kept stationary. The resistance of the blank insert is normally in the 80 to 200  $\Omega$  range, depending on the brand and size.

**NOTE:** During normal usage, it is helpful to write down the resistance range of each particular type of blank insert with the specific culture media used. If the electrode is subsequently suspected of having a problem, a comparison of current readings to past readings on the same blank insert and culture media could assist in determining if the electrode is functioning as expected.

---

## 1. Warning tone sounds when the “Measure” button is pressed

This indicates that the circuit is open and current is unable to flow. Causes may include the following:

- a. The “measure” button was pressed while the electrode was not immersed in solution.
- b. If the warning tone sounds with the electrode immersed in solution and the meter display off-scale, then the current electrode circuit is broken and the electrode needs to be replaced.
- c. If the electrode is in solution and the warning tone sounds discontinuously, a reading may be displayed, but it is likely not very stable. This indicates that there could be a large offset potential between the two current electrodes that cannot be overcome by the system. The offset could be due to contamination on the current electrode surface. That can be corrected by cleaning the surface of the electrode (see the section on Cleaning the Electrode). This could also be caused by electrochemical corrosion in the electrode that occurs when the sealing property of the adhesive fails. In this case, the electrode needs to be replaced.

## 2. Meter reading is not stable when the power is turned on

Check the **Mode** switch: if it is in V mode, the display will not be stable when the electrode is not in the solution. This is normal. If the meter is in R mode, the meter display should read zero unless the “Measure R” button is pressed. If it does not, the meter is malfunctioning. Call WPI Technical Support for assistance.

## 3. Non-zero reading when measuring voltage

The electrode is dirty or not preconditioned. Clean the electrode as suggested above. Soak the electrode in electrolyte overnight with cable connected to **EVOM**. Make sure the meter is turned off. After overnight soaking, adjust the Voltage zero to eliminate any residual offset voltage.

## 4. Unstable resistance reading

Resistance measurements using the **STX2** electrode are sensitive to the position of the electrode. Moving the electrode will cause the reading to change. This is normal. However, if the electrode is held in a fixed position and the reading is unstable, there could be several possible causes:

- a. The electrode is dirty and needs to be cleaned (see the section on Cleaning the Electrode).
- b. The electrode and its cable are too close to a strong electromagnetic radiation

device or power line or are connected to a computer with an unshielded power supply. Moving the system to a different area or removing the connection to the computer, will eliminate that problem

- c. The electrode is broken and needs to be replaced.

## 5. Voltage reading drifts

Possible causes include:

- a. The electrode is not equilibrated. See the “Electrode Preparation” Section of the manual.
- b. The electrode is dirty. Clean the electrode (see the section on Cleaning the Electrode).
- c. The electrode and its cable are too close to a strong electromagnetic radiation device or power line or are connected to a computer with an unshielded power supply. Moving the system to a different area or removing the connection to the computer, will eliminate that problem.
- d. The electrode is broken and needs to be replaced.

## 6. Meter is not reading within 1% of 1000 ohm during Meter Self-Test

Possible causes include:

- a. Low batteries: Check and change the batteries as necessary.
- b. “Zero $\Omega$ ” is not adjusted correctly. See INSTRUMENT SELF-TESTS: Testing the Electrode for Resistance Measurements.
- c. System requires calibration: as the meter ages, the test reading is expected to drift slightly downward. However, this drift is normal within 1% accuracy at 1000 ohm. If the error is more than 1% ( $>10\Omega$ ), then, the accuracy of your measurement will have a error that is larger than 1%. In that case, it is recommended that WPI recalibrate the instrument.

## 7. Resistance reading is lower than expected

If the resistance reading of the “blank” is close to the normal value and the tissue resistance reading is stable and repeatable, perform the Instrument Self-Test to confirm that the meter is functioning appropriately. If the reading continues to be lower than expected and the meter has satisfactorily met the Instrument Self-Testing criteria, the likely cause is a problem with the cell culture, *e.g.*, the cells are contaminated with something that is affecting their ability to grow to confluence. Electrode failure will not cause a lower than expected yet stable reading.

---

## **8. Resistance reading is higher than expected**

If the resistance readings (including the blank and cell culture) are much greater than expected, perform the Instrument Self-Test to confirm that the meter is functioning appropriately. If the problem persists, the likely cause is the electrode. Try cleaning the electrode (see the section on Cleaning the Electrode). If the problem is not corrected, this indicates a failure of the electrode and the electrode needs to be replaced.

## **SPECIFICATIONS**

Membrane Voltage Range	$\pm 199.0$ mV
Resistance Range	0 to 1999 $\Omega$ & 0 to 20 K $\Omega$
AC Square Wave Current	2k Range: $\pm 20$ $\mu$ A @ 12.5 Hz 20k Range: $\pm 2$ $\mu$ A @ 12.5 Hz
Power	One 9-V alkaline battery, six 1.5-V alkaline AA cells.
BNC Output of EVOMX	1 $\Omega$ /mV, when the Range Toggle Switch is at 2000 $\Omega$ . 10 $\Omega$ /mV, when the Range Toggle Switch is at 20 K $\Omega$ .
Dimensions	20 cm x 10 cm x 5 cm
Weight	3 lb (1.4 kg)

---

## APPENDIX A: SUMMARY OF OPERATING INSTRUCTIONS

### For Resistance Measurements:

- Turn on **EVOM**
- In the R mode, adjust the “Zero  $\Omega$ ” screw with a small flat-head screwdriver until the meter shows a reading of 0.
- Connect the electrodes
- Sterilize the electrodes (optional)
- Perform measurements

### For Voltage Measurements:

- Connect the electrodes to the EVOM
- Equilibrate the electrodes with the power off
- Sterilize the electrodes (optional):
- Turn on **EVOM**
- After 15 min., in the V mode, adjust the “Zero V” screw with a small flat-head screwdriver until the meter shows a reading of 0.0 mV.
- Perform measurements



## APPENDIX B: IMPORTANT APPLICATION NOTES

### Resistance value of the “blank” insert

When using an **EVOM** with an **STX2** to measure a blank insert, the resistance value is typically between 120 to 180  $\Omega$ , depending on the specific brand of the insert. Many users mistakenly think this background resistance is due to the resistance of the blank filter. However, if the filter membrane is removed from the insert, the resistance reading of the insert will remain the same. This is because the background resistance reading is due mainly to the small gap between the bottom of the cell culture insert and the bottom of the cell culture plate. See Fig. 1. This gap is about 1 mm, with some insert brands having a slightly larger gap than others. The variation in this gap is the cause of the difference between blank readings of different brands: the smaller the gap, the higher the electric resistance. *The resistance of the filter membrane itself is actually negligible.* If an **Endohm-24SNAP** or **Endohm-12** chamber is used, the blank resistance becomes near zero because the external electrode is directly underneath the filter and the gap does not exist.

### Special Note: 24 mm diameter (6-well) inserts and STX electrodes

Note that the resistance readings from 24 mm diameter tissue culture inserts (used in 6-well plates) obtained by using WPI's STX series of electrodes will be 1.8 to 2.2 times higher than that obtained using the **Endohm-24**. This is because the STX electrode cannot deliver a uniform current density over the relatively large membrane through the small gap between the membrane and the bottom of the well. *Therefore, the resistance reading of a 24 mm (6-well) diameter insert obtained by STX electrodes should not be used to calculate the unit area resistance.* STX electrodes are only intended for providing a qualitative measurement of cell monolayer health and quantitative measurement of cell confluence. This is not a problem with smaller inserts, such as the 12 mm and 6 mm diameter inserts, because of the relatively smaller size of the membrane compared to the electrode. When **EVOM** is used with the **Endohm**, it gives a repeatable and accurate value of membrane resistance consistent with that obtained by using a well-designed Ussing chamber. It is also consistent with that obtained by the **STX2** electrode for the 12 mm and 6 mm diameter filter inserts.

**Note:** The unit area resistance is independent of the area of the membrane and may be used to compare data obtained from inserts of different sizes.

---

## Improving the Accuracy and Repeatability of the System

For measuring low-resistance tissue culture, or for more precise measurement, the user should consider using the **Endohm** chamber instead of **STX2** electrode. Although cells must be transferred from their culture wells to the Endohm chamber for measurement, more accurate measurement of membrane resistance can be achieved. By introducing concentric pairs of electrodes above and beneath the membrane, the **Endohm** reduces background resistance (with a blank cup inserted) from 150  $\Omega$  to less than 5  $\Omega$  (except **Endohm-6**, which is higher). The shape of the current electrodes allows a more uniform current density to flow across the membrane. With fixed electrode geometry, the variation of readings on the same sample is 1-2  $\Omega$  as compared to 5-10% of the total reading using the **STX2** electrodes. The **Endohm**, together with the **EVOM**, offer the most accurate, convenient and economical solution for trans membrane electrical resistance measurement.

## APPENDIX C: RESISTANCE CALCULATIONS

### Resistance

The value of the blank always adds to the total resistance measured across a tissue culture membrane (see Appendix B for a more detailed discussion of the source of the blank resistance). *The blank resistance must be measured and then subtracted from the resistance reading across tissue in order to obtain the true tissue resistance.*

For example, suppose the resistance through a 0.15 M KCl solution and across the membrane support (with no tissue present) of a Falcon 12-well cell culture insert measures 130  $\Omega$ . This is the blank reading for that cell culture insert. (Resistance may vary for culture cups made by other manufacturers.) In this example, using 800  $\Omega$  as the sample measurement, the calculated resistance for the tissue itself – R (tissue) – is:

1.  $R_{(\text{blank})} = 130 \Omega$
2.  $R_{(\text{blank})} + R_{(\text{tissue})} = R_{(\text{Total})} = 800 \Omega.$
3.  $R_{(\text{true tissue})} = R_{(\text{Total})} (800 \Omega) - R_{(\text{blank})} (130 \Omega) = 670 \Omega$

### Unit Area Resistance

As the resistance is inversely proportional to the area of the tissue, instead of reporting resistance, typically the product of the resistance and the area is calculated and reported. The unit area resistance is independent of the area of the membrane used and may be used to compare data obtained from inserts of different sizes.

**NOTE:** Resistance readings for 24 mm or larger diameter inserts obtained by using the **EVOM** with the **STX2** electrode should *not* be converted to unit area resistance. The **Endohm** is recommended for these larger inserts. See additional discussion of this point in the section in APPENDIX B entitled “Special Note: 24 mm diameter (6-well) inserts and STX electrodes”.

The **unit area resistance** is obtained by **multiplying** the meter readings by the effective surface area of the filter membrane. The dimension is  $\Omega\text{cm}^2$ . This is because the resistance is *inversely* proportional to the surface area. Thus, the larger the membrane, the lower the resistance.

---

**Resistance of a unit area = Resistance ( $\Omega$ ) x Effective Membrane Area\* ( $\text{cm}^2$ )**

\* See manufacturing specifications for the particular insert

$$\text{Unit Area} = 1 \text{ cm}^2$$

**The unit area resistance is independent of the area of the membrane used and may be used to compare data obtained from inserts of different sizes.**

Continuing with the previous example, in which the  $R_{\text{(true tissue)}} = 670 \Omega$ , if an effective membrane diameter were 1.05 cm, the unit area resistance would be:

$$\begin{aligned} \text{Resistance x Effective Membrane Area} &= 670 \Omega \times \pi d^2 / 4 \\ &= 670 \Omega \times (3.14) (1.05 \text{ cm})^2 / 4 \\ &= 580 \Omega\text{cm}^2 \end{aligned}$$

580  $\Omega$  is the resistance of a unit area of 1  $\text{cm}^2$ .

The larger the membrane, the lower the resistance. The dimension is  $\Omega\text{cm}^2$ , not  $\Omega/\text{cm}^2$ . This may be confusing to a new user who might expect to divide to find the resistance of a unit area.

A further illustration may help to reinforce this concept:

Assuming a 1  $\text{cm}^2$  membrane has a resistance of 500  $\Omega$ , then a 5  $\text{cm}^2$  membrane will have a resistance of 100  $\Omega$ , not 2500  $\Omega$ , because the resistance is *inversely* proportional to the area. Accordingly, if a 5  $\text{cm}^2$  membrane has a resistance of 100  $\Omega$ , then the resistance of a 1  $\text{cm}^2$  membrane will be  $100 \Omega \times 5 \text{ cm}^2 = 500 \Omega\text{cm}^2$  because the smaller membrane is 1/5 the size and the resistance will therefore be 5 times greater.

## **WARRANTY**

WPI (World Precision Instruments, Inc.) warrants to the original purchaser that this equipment, including its components and parts, shall be free from defects in material and workmanship for a period of one year\* from the date of receipt. WPI's obligation under this warranty shall be limited to repair or replacement, at WPI's option, of the equipment or defective components or parts upon receipt thereof f.o.b. WPI, Sarasota, Florida U.S.A. Return of a repaired instrument shall be f.o.b. Sarasota.

The above warranty is contingent upon normal usage and does not cover products which have been modified without WPI's approval or which have been subjected to unusual physical or electrical stress or on which the original identification marks have been removed or altered. The above warranty will not apply if adjustment, repair or parts replacement is required because of accident, neglect, misuse, failure of electric power, air conditioning, humidity control, or causes other than normal and ordinary usage.

To the extent that any of its equipment is furnished by a manufacturer other than WPI, the foregoing warranty shall be applicable only to the extent of the warranty furnished by such other manufacturer. This warranty will not apply to appearance terms, such as knobs, handles, dials or the like.

WPI makes no warranty of any kind, express or implied or statutory, including without limitation any warranties of merchantability and/or fitness for a particular purpose. WPI shall not be liable for any damages, whether direct, indirect, special or consequential arising from a failure of this product to operate in the manner desired by the user. WPI shall not be liable for any damage to data or property that may be caused directly or indirectly by use of this product.

## **Claims and Returns**

• Inspect all shipments upon receipt. Missing cartons or obvious damage to cartons should be noted on the delivery receipt before signing. Concealed loss or damage should be reported at once to the carrier and an inspection requested. All claims for shortage or damage must be made within 10 days after receipt of shipment. Claims for lost shipments must be made within 30 days of invoice or other notification of shipment.

Please save damaged or pilfered cartons until claim settles. In some instances, photographic documentation may be required. Some items are time sensitive; WPI assumes no extended warranty or any liability for use beyond the date specified on the container.

• WPI cannot be held responsible for items damaged in shipment en route to us. Please enclose merchandise in its original shipping container to avoid damage from handling. We recommend that you insure merchandise when shipping. The customer is responsible for paying shipping expenses including adequate insurance on all items returned.

• Do not return any goods to WPI without obtaining prior approval and instructions (RMA#) from our returns department. Goods returned unauthorized or by collect freight may be refused. The RMA# must be clearly displayed on the outside of the box, or the package will not be accepted. Please contact the RMA department for a request form.

• Goods returned for repair must be reasonably clean and free of hazardous materials.

• A handling fee is charged for goods returned for exchange or credit. This fee may add up to 25% of the sale price depending on the condition of the item. Goods ordered in error are also subject to the handling fee.

• Equipment which was built as a special order cannot be returned.

• Always refer to the RMA# when contacting WPI to obtain a status of your returned item.

• For any other issues regarding a claim or return, please contact the RMA department

***Warning: This equipment is not designed or intended for use on humans.***

*\* Electrodes, batteries and other consumable parts are warranted for 30 days only from the date on which the customer receives these items.*



**WORLD PRECISION INSTRUMENTS, INC.**

175 Sarasota Center Boulevard  
Sarasota, FL 34240-9258 USA

Telephone: (941) 371-1003 Fax: (941) 377-5428  
e-mail wpi@wpiinc.com

**DECLARATION OF CONFORMITY**

We: World Precision Instruments, Inc.  
175 Sarasota Center Boulevard  
Sarasota FL 34240-9258  
USA

as the manufacturers of the apparatus listed, declare under sole responsibility that the product(s):

**Title: EVOM and EVOMX (Millicel-ERS)**

to which this declaration relates is/are in conformity with the following standards or other normative documents:

**Safety:** EN 61010-1:1993 (IEC 1010-1:1990)

**EMC:** EN 50081-1:1992  
EN 50082-1:1992

and therefore conform(s) with the protection requirements of Council Directive 89/336/EEC relating to electromagnetic compatibility and Council Directive 73/23/EEC relating to safety requirements.

**Issued on: 18<sup>th</sup> February 2000**

  
Dr. Mark P. Broderick  
President and COO

World Precision Instruments, Inc.  
175 Sarasota Center Boulevard  
Sarasota, FL 34240-9258 USA

  
Mr. Glen Carlquist  
Production Manager

World Precision Instruments, Inc.  
175 Sarasota Center Boulevard  
Sarasota, FL 34240-9258 USA





## ***World Precision Instruments, Inc.***

### **USA**

International Trade Center, 175 Sarasota Center Boulevard, Sarasota FL 34240-9258  
Tel: 941-371-1003 • Fax: 941-377-5428 • E-mail: sales@wpiinc.com

### **UK**

Astonbury Farm Business Centre • Aston, Stevenage, Hertfordshire SG2 7EG  
Tel: 01438-880025 • Fax: 01438-880026 • E-mail: wpiuk@wpi-europe.com

### **Germany**

Liegnitzer Str. 15, D-10999 Berlin  
Tel: 030-6188845 • Fax: 030-6188670 • E-mail: wpide@wpi-europe.com

### **Internet**

**[www.wpiinc.com](http://www.wpiinc.com) • [www.wpi-medical.com](http://www.wpi-medical.com) • [www.nitricoxide.net](http://www.nitricoxide.net) • [www.pipetter.com](http://www.pipetter.com)**