

Model '11' Plus

Syringe Pump

User's Manual

Single Syringe Pump 70-2208

Dual Syringe Pump 70-2209

Single Syringe Pump with Serial Communication 70-2211

Dual Syringe Pump with Serial Communication 70-2212

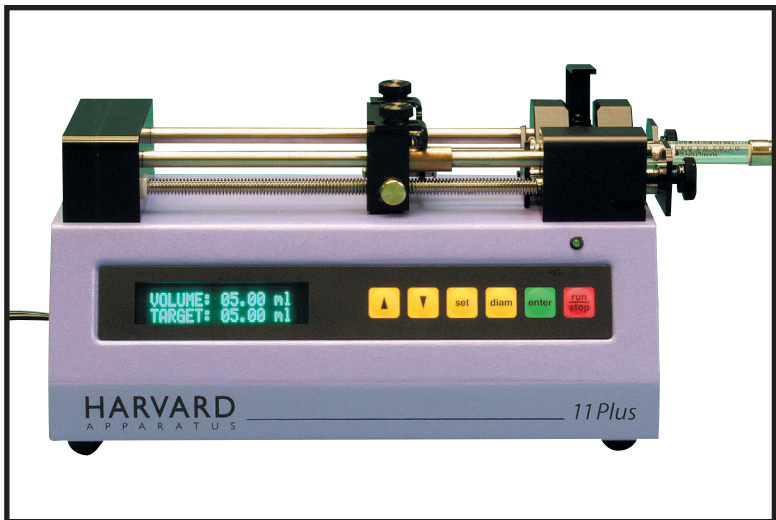

HARVARD

A P P A R A T U S

Table of Contents

SUBJECT	PAGE NO.
Table of Contents	1
General Information - Warranty and Repairs	2
General Safety Summary	3-4
Introduction	5-6
Theory of Operation.....	5
Features	5
Pump 11 Plus, Front and Rear Views	6
Installation	7
Initial Setup & Location Requirements.....	7
Loading the Syringe	7
Limit Switch Calibration	7
Operation	8
Getting Started	8
Turn Pump ON	8
Function Keys and Run Indicator	8
Entering Syringe Size	9
Entering Flow Rate Range	9
Entering Flow Rate	9
Press Run	9
Check Syringe.....	9
Advanced Features	10
Volume Mode	10
Power Failure	10
Display Intensity.....	11
Changing Rates	11
Infuse/Withdraw Switch	11
Maintenance	11
Protecting Small, Fragile Syringes	12
Remote Communication	12
Appendices	
A. Specifications	13
B. Table of Popular Syringe Diameters.....	14
C. Table of Minimum and Maximum Flow Rates	15
D. Serial Communications; Commands, Queries and Responses	16,17
E: Serial Port Connections: Dual RS-232.....	18
Daisy-Chain.....	18

General Information

Serial Number

All inquiries concerning our product should refer to the serial number of the unit. Serial numbers are located on the rear of the chassis.

Calibration

All syringe pumps are designed and manufactured to meet their performance specifications at all rated voltages and frequencies. A calibration certificate is available upon request. Contact customer service for details and pricing.

Warranty

Harvard Apparatus warrants this instrument for a period of one year from date of purchase. At its option, Harvard Apparatus will repair or replace the unit if it is found to be defective as to workmanship or material.

This warranty does not extend to damage resulting from misuse, neglect or abuse, normal wear and tear, or accident.

This warranty extends only to the original customer purchaser.

IN NO EVENT SHALL HARVARD APPARATUS BE LIABLE FOR INCIDENTAL OR CONSEQUENTIAL DAMAGES. Some states do not allow exclusion or limitation of incidental or consequential damages so the above limitation or exclusion may not apply to you. **THERE ARE NO IMPLIED WARRANTIES OF MERCHANTABILITY, OR FITNESS FOR A PARTICULAR USE, OR OF ANY OTHER NATURE.** Some states do not allow this limitation on an implied warranty, so the above limitation may not apply to you.

If a defect arises within the one-year warranty period, promptly contact your local distributor or Harvard Apparatus, Inc. 84 October Hill Road Holliston, Massachusetts 01746-1388 using our toll free number 1-800-272-2775 (valid only in the U.S., outside U.S. call 508-893-8999). Goods will not be accepted for return unless an RMA (returned materials authorization) number has been issued by our customer service department. The customer is responsible for shipping charges. Please allow a reasonable period of time for completion of repairs, replacement and return. If the unit is replaced, the replacement unit is covered only for the remainder of the original warranty period dating from the purchase of the original device.

This warranty gives you specific rights, and you may also have other rights which vary from state to state.

Repair Facilities and Parts

Harvard Apparatus stocks replacement and repair parts. When ordering, please describe parts as completely as possible, preferably using our part numbers. If practical, enclose a sample or drawing. We offer a complete reconditioning service.

CAUTION

This pump is not registered with the FDA and is not for clinical use on human or veterinary patients. It is intended for research use only.

CAUTION
FOR RESEARCH USE ONLY
NOT FOR CLINICAL
USE ON PATIENTS

General Safety Summary

Please read the following safety precautions to ensure proper use of your syringe pump. To avoid potential hazards and product damage, use this product only as instructed in this manual. If the equipment is used in a manner not specified by the manufacturer, the protection provided by the equipment may be impaired.

To Prevent Hazard or Injury:

Use Proper Power Supply

The pump is supplied with an approved power supply and line cord. To maintain the safety integrity of the device, use only one of the following power supplies:

Ault Inc.

Model:	PW118
Output:	12 Vdc, 1.5 A,
Input:	100-250 Vac, 50-60 Hz, .5A

Cui Inc.

Model:	SA06N12-V
Output:	12 Vdc, 2.0 A
Input:	100-240 Vac, 50-60 Hz, .8A

Globtek Inc

Model:	GT-4201D-12
Output:	12 Vdc, 1.66 A
Input:	100-240 Vac, 50-60 Hz, 0.6A

Use Proper Line Cord

Use only the line cord shipped with the product and make sure line cord is certified for country of use.

Ground the Product

This product is grounded through the return path of the DC power supply. To avoid electric shock, use only approved power supply and line cord with the product.

Make Proper Connections

Make sure all connections are made properly and securely.

Observe all Terminal Ratings

Review the operating manual to learn the ratings on all connections.

General Safety Summary

4

Harvard Apparatus Pump '11' Plus Syringe Pump

Avoid Exposed Circuitry

Do not touch any electronic circuitry inside of the product.

Do Not Operate with Suspected Failures

If damage is suspected on or to the product do not operate the product. Contact qualified service personnel to perform inspection.

Observe all Warning Labels on Product

Read all labels on product to ensure proper usage.



CAUTION
Refer to Manual



*Functional Ground
Terminal*

Environmental Conditions

Indoor use only

Temperature 4°C to 40°C (40°F to 104°F)

Humidity 20% to 80% RH

Well Ventilated Room

Altitude up to 2000 m

Mains Voltage Fluctuation not to Exceed +/- 10% of Nominal

Transient Overvoltage, Category II

Pump is Rated Pollution Degree 2 in Accordance with IEC 664

Introduction

Theory of Operation:

The Pump '11' Plus is designed as a low cost, single or dual syringe infusion pump capable of low to moderate back pressures. The Pump '11' Plus is standard with an infuse limit switch and anti-siphon brackets. Both the single and dual syringe versions are available with our serial communication option package that includes dual RS232, reversing switch, and a withdraw limit switch.

The pump can hold syringes of any make from 0.5 μ l to 50/60ml for the single syringe version and from 0.5 μ l to 10ml for the dual syringe version. The diameter of the syringes is entered via the keypad and the internal microprocessor drives a precision stepper motor to produce accurate fluid flow.

Nonvolatile memory stores the last syringe diameter and flow rate along with other configuration data.

The "Power Failure Mode" can be set to either turn the pump off in the event of power failure or to resume pumping when power resumes.

Features:

Bright Display and Easy-To-Use Interface

A two-line 16 character vacuum fluorescent display along with six membrane keys make this a most attractive but powerful, easy-to-use syringe pump. Only two entries required to start pumping; syringe Inside Diameter (mm) and pumping flow rates. The Flow rate can be changed while the Pump is running.

Two Modes of Operation, Constant Flow Rate and Volume Dispense

The Pump '11' Plus will operate continuously in RATE mode or accurately dispense a specific amount of fluid in VOLUME mode.

Smooth Flow

Enhanced micro-stepping pump profiles deliver very smooth and consistent flow, that is virtually pulse free.

Nonvolatile Memory

The pump remembers its last syringe size, flow rate used and configuration settings.

Power Fail Mode

In a power failure the Pump can either RESUME or STOP pumping when power is returned.

CE Mark Approved

The Pump '11' Plus meets all relevant European EMC and Safety requirements for laboratory equipment.

Pump '11' Plus Front and Rear Views

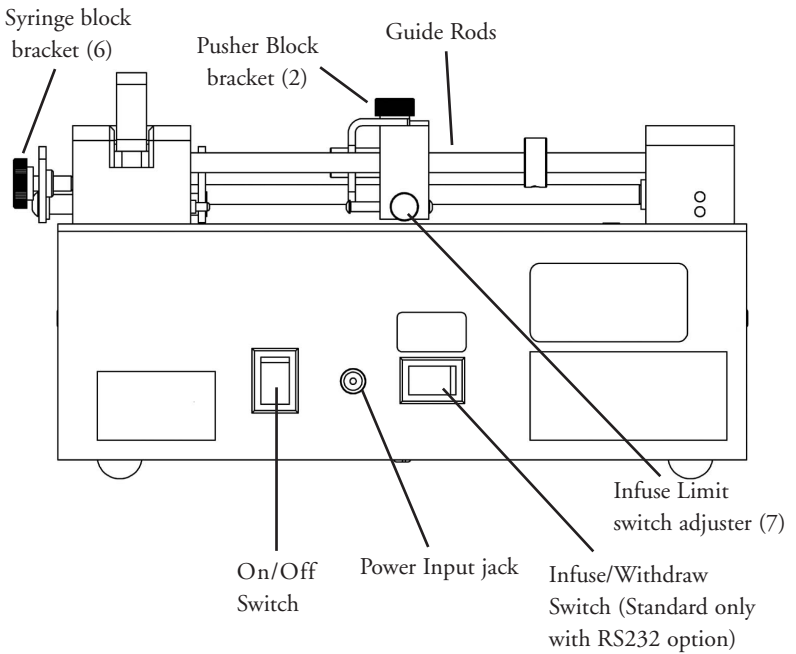
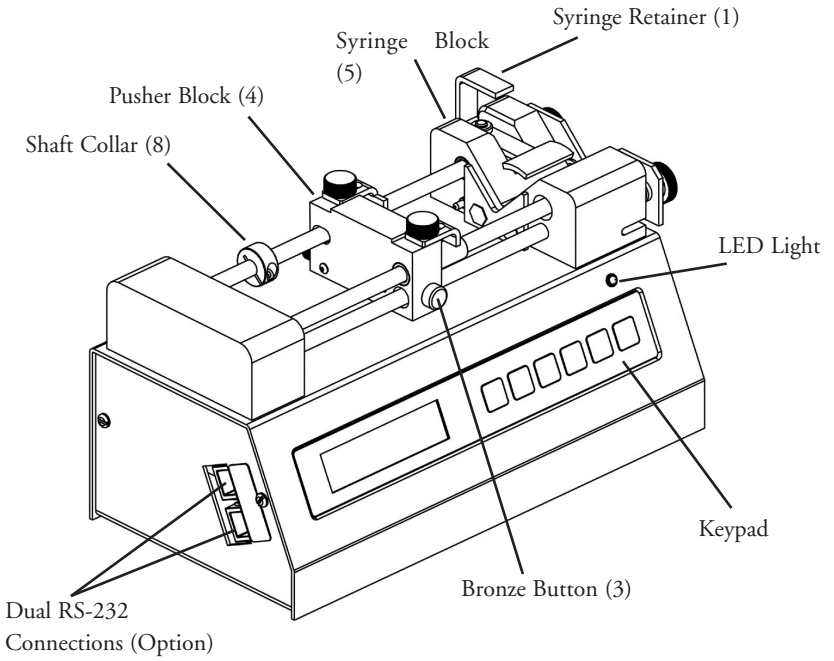

Installation

7

Initial Setup

1. Read the manual to become familiar with all features and functions of the Pump '11' Plus.
2. Connect the external DC Power Supply and line cord to the pump and main supply.
3. Turn on main power switch located on the rear panel. The display will now illuminate indicating that the power connections are correct. The display will indicate POWER FAIL. (this is normal as the pump indicates on the display if power was disrupted since last use.)

Location Requirements for the Syringe Pump

- A sturdy, level, clean and dry surface
- Minimum of one inch (2cm) clearance around the pump
- Appropriate environmental conditions
- A well ventilated room

Loading the Syringe & Limit Switch Calibration

1. Release the Syringe pusher block (4) by pressing the bronze button (3) on the side of the pusher.
2. While holding the bronze button 'in', slide the pusher to the right.
3. Raise the spring loaded syringe retainer (1) and swing it out of the way.
4. Lay the loaded syringe in the 'V' shaped syringe block (5).
5. Swing the syringe retainer (1) so it holds the syringe in place.
6. Move the pusher so it makes contact with the syringe plunger.
7. Adjust pusher block Thumbscrews & bracket (2) until the syringe plunger is completely captured.
8. Tighten down thumbscrews on syringe block bracket (6) so that it captures flanges on syringe barrel.
9. The Infuse limit switch can be easily adjusted by loosening the thumbscrew (7) on the pusher block and sliding the dowel pin in or out to the desired position. Tighten thumbscrew into place when switch is set.
10. For units with RS232 option, the Withdraw limit switch is adjusted via the shaft collar (8). Slide the collar to the desired position, and use the hex key provided to lock it into place.

Operation: Getting Started

Getting started

1. Turn Pump 'ON'

Turn on power using the switch on rear of the pump, the display will light, and indicate POWER FAIL. (this is normal as the pump indicates on the display if power was disrupted since last use.)

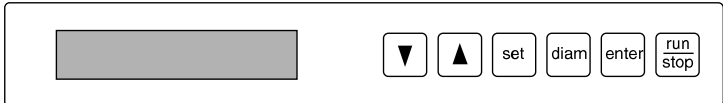

2. Function Keys and Run Indicator

Refer to the colored keypad at the front of the pump to identify the following functions starting from the right.

RUN/STOP – This turns the pump motor on and off.

ENTER – This key enters the data that is on the display into the memory of the pump. Also used to query the flow rate.

DIAM – Used to enter or query the syringe diameter.

SET – This key is used to select which digit of the display is to be changed, to move the decimal point and to move between modes. Each time the set key is pressed the underline cursor below the digit or character on the display moves one step to the right. It is used in conjunction with the ascending and descending keys. When it the display shows the desired the correct value the set key will advance right to the next digit.

△▽ – The ascending and descending keys are used to change the numbers on the display. △ Up key makes numbers increase, ▽ Down Key makes numbers decrease. When the underline cursor is placed below the decimal point, the △▽ keys shift the decimal one place up or down.

Run Indicator – When the pump is running, the highly visible, green LED above the RUN/STOP key will illuminate.

Operation: Getting Started

3. *Enter Syringe Size*

Enter the inside diameter (ID) of the syringe you wish to use. Units are in millimeters (mm).

If you do not know your syringe diameter, refer to appendix B for nominal inside diameters of most popular syringes. For the greatest accuracy or if your syringe is not listed in appendix B, measure the inside diameter with a vernier caliper or other precision measuring tool. Record this value for future use.

Press SET followed by the DIAM key. The previously used diameter will appear on the display. The underline cursor will appear under the left-most digit or decimal point. The Δ and ∇ keys are used to scroll to the desired number and the SET key moves the underline cursor one place to the right. Once the desired diameter is displayed, press the ENTER key to place this value into memory.

4. *Enter Flow Rate Range*

Choose your flow rate units; either microliters or milliliters, per minute or per hour.

From the initial RATE VOL CONFIG menu, using the Δ or ∇ key, move the underline cursor under the CONFIG mode menu prompt. Press the SET key to enter the CONFIG mode. Press the SET key again to move the underline cursor to the flow rate choices. Choose your flow rate units while in the SET:UNITS mode by pressing the Δ or ∇ keys to scroll the four flow rate choices; ml/min, μ l/min, ml/hr, μ l/hr. Once the desired flow rate units are displayed, press the ENTER key to return to the main SET:CONFIG mode. Press SET or ENTER again to put your desired flow rate units into memory and return to the RATE VOL CONFIG menu. These units will be the same for infuse and withdraw.

5. *Enter Flow Rate*

From the initial RATE VOL CONFIG menu, press the SET key to enter the SET:RATE mode. Each time you change the syringe diameter, the previously used flow rate is erased. If the syringe diameter is unchanged, the previously used flow rate will appear on the display. The underline cursor will appear under the left-most digit or decimal point. The Δ and ∇ keys are used to scroll to the desired number and the SET key moves the underline cursor one place to the right. Once the desired rate is displayed, press the ENTER key to place this value into memory. This value will be the same for infuse and withdraw.

6. *Press RUN*

Press the RUN/STOP key to start pump and begin pumping. The Run Indicator (Green LED above the RUN/STOP key) will light when the pump is on and pumping.

7. *Check Syringe Often*

The Pump 11 Plus will shut itself off via the limit switches. It will not shut off if the switches are set incorrectly, and the syringe is empty or otherwise overloaded. Although this presents no hazard to the user or the pump, it is prudent to check the syringe from time to time.

Operation: Advanced Features

1. Volume Mode

The Pump 11 Plus can be set to dispense a precise volume and then stop. To activate the volume dispense mode a target volume must be set.

To set a target volume, at the RATE VOL CONFIG display, move the underline cursor, using the Δ or ∇ key, to VOL. Press the SET key to enter the VOL set mode. Use the Δ or ∇ key and the SET key to display a target volume from 00.01 to 99.99. Volume units are either ml (milliliters) or μ l (microliters). Target volume units are established in the CONFIG SET:UNITS mode; example: if your pumping units are ml/ min or ml/ hr, then the volume dispense units will be ml's. Press the ENTER key to select the desired target volume. Exit the VOL mode by pressing the ENTER key.

Once you press the RUN key, the pump will run until the target volume is delivered. The display will show the actual volume dispensed along with the target volume. Press the RUN key each time you want to repeat the volume dispense. If you press the STOP key during a volume dispense, you can restart the pump at the place you stopped by pressing the RUN key again.

To exit the volume dispense mode, set the target volume to 00.00 or turn off and on the pump via the main power switch. NOTE: In the event of a power failure, the actual dispensed volume and the target volume are not retained in memory. This means that while in volume dispense mode, if a power failure occurred, the pump would not resume volume dispense pumping even if the POWER ON mode was set to run. This mode will function for both infuse and withdraw.

2. Power Failure

In the event of a momentary or prolonged power failure, the Pump 11 Plus can be set to either;

- a) Resume pumping when power is returned, with "POWER FAIL" on the display.
- b) Not start pumping when power is returned, with "POWER FAIL" on the display.

To set the power fail mode, at the RATE VOL CONFIG display, move the underline cursor, using the Δ or ∇ key, to CONFIG. Press the SET key to enter the CONFIG mode options. Use the Δ or ∇ key to scroll the CONFIG options until you reach the SET:POWER ON: display. Press the SET key again moving the underline cursor to the right. Use the Δ or ∇ key to scroll the POWER:ON choices; 'stop' or 'run'. Press the ENTER key to select either mode. Exit the CONFIG mode by pressing the ENTER key again and save the POWER:ON setting in memory.

Operation: Advanced Features

3. *Display Intensity*

For varying light conditions, four levels of intensity can be set on the vacuum fluorescent display

To set the desired display intensity, at the RATE VOL CONFIG display, move the underline cursor, using the Δ or ∇ key, to CONFIG. Press the SET key to enter the CONFIG mode options. Use the Δ or ∇ key to scroll the CONFIG options until you reach the SET:INTENSITY:. Press the SET key again moving the underline cursor to the right. Use the Δ or ∇ key to scroll the SET : INTENSITY choices; "1", "2", "3", "4" (4 is highest intensity, 1 is the lowest intensity). Press the ENTER key to select the desired display intensity. Exit the CONFIG mode by pressing the ENTER key again and save the INTENSITY setting in memory.

4. *Changing Rates*

If the pump is running at an existing rate it will continue to do so until a new rate is entered. Except for volume mode, the flow rate can be changed while the pump is running. As soon as the ENTER key is pressed the pump will change to the new flow rate. To change rates from the keypad, while in volume mode, the pump must be stopped first.

5. *Infuse/Withdraw Switch Operation (standard with RS232 option)*

For customer convenience, a two position rocker switch is included in the Pump '11' Plus Advanced for changing from infuse to withdraw on the fly. When the pump is infusing, and the switch is toggled, the pump will now be in the withdraw mode. Switch the toggle again, it puts it back into infuse mode. The physical position of the switch does not matter. The pump always powers up in infuse mode.

6. *Maintenance*

Keep the pump clean and dry. Avoid liquid spills that may find their way into the electronics.

A small container of grease is provided for periodic lubrication of the lead screw and guide rods. It is important to keep these guide rods clean and lubricated.

To clean the exterior surfaces, use a lint-free cloth to remove loose dust. Use care to avoid scratching the display window. For more efficient cleaning, use a soft cloth dampened with water or an aqueous solution of 75% isopropyl alcohol.

If the pump does not work properly, contact Harvard Apparatus for appropriate instructions.

Operation: Advanced Features

7. *Protecting Small, Fragile Syringes*

The Pump 11 Plus will hold microliter size syringes down to 10 μ l size. These small syringes have fine wire plungers that may be damaged if allowed to bottom out. The pump is equipped with limit switches to help in avoiding this problem. (See page 7 for instructions on use.)

8. *Remote Communication*

The Pump 11 Plus with RS232 option is equipped at the factory for remote serial communications. The baud rate and address are set in the CONFIG mode options.

a. Pump Address

To set the pump address, at the RATE VOL CONFIG display, move the underline cursor, using the Δ or ∇ key, to CONFIG. Press the SET key to enter the CONFIG mode options. Use the Δ or ∇ key to scroll the CONFIG options until you reach the SET:ADDRESS. Press the SET key again moving the underline cursor to the right. Use the Δ or ∇ key to scroll the two digit number fields. Use the Δ or ∇ key and the SET key to display a unique pump address from 00 to 99. Press the ENTER key to select the desired pump address. Exit the CONFIG mode by pressing the ENTER key again and save the ADDRESS setting in memory.

b. Baud Rate

To set the pump Baud Rate, at the RATE VOL CONFIG display, move the underline cursor, using the Δ or ∇ key, to CONFIG. Press the SET key to enter the CONFIG mode options. Use the Δ or ∇ key to scroll the CONFIG options until you reach the SET:BAUD. Press the SET key again moving the underline cursor to the right. Use the Δ or ∇ key to scroll the SET:BAUD choices; '300', '1200', '2400' or '9600'. Press the ENTER key to select the desired baud rate. Exit the CONFIG mode by pressing the ENTER key again and save the BAUD setting in memory.

Appendix A

Pump '11' Plus Specifications

Type	Microprocessor single or dual syringe
Syringe/Size for Pump '11' with Holder For:	Plastic or glass
1 Syringe	From 0.5 μ l to 50/60 ml
2 Syringe	From 0.5 μ l to 10 ml
Flow Rate Range:	
Minimum / Maximum	0.0014 μ l/hr with 0.5 μ l syringe / 26.55 ml/min with 50/60 ml syringe
Flow Rate Accuracy	\pm 0.5%
Calibration	Automatic, enter syringe size up to 35 mm Inside Diameter
Display	2 line, 16 character vacuum, fluorescent display and green run led
Nonvolatile Memory	Stores diameter, rate and configuration settings
Maximum Force	8 kg (17 lb.)
Maximum Pressure	8 p.s.i. with 50/60 cc syringe; 100 p.s.i. with 1 ml syringe
Drive Motor	0.9° step angle motor
Step Rate:	
Minimum / Maximum	1 pulse in 27.6 sec / 200 steps/sec
Pusher Advance/Step	0.8 μ m pusher advance per motor step
Pusher Travel Rate:	
Minimum / Maximum	0.7 μ m/min / 15 mm/min
Dynamic Range	1 to 16,384
Leakage to Ground	Typically < 150 μ A
Ground Resistance	Typically < 0.05 ohms
Input Power	12 VDC 1.5Amps
Input Power Connection	2.5mm ID x 5.5mm OD male plug
Power Supply	100/250 VAC, 50/60 Hz, 18 Watts Universal Power Supply, Use Only a Harvard Apparatus Approved Power Supply and Line Cord
Size, H x W x D	11.4 x 22.9 x 11.4 cm (4-1/2 x 9 x 4-1/2 in)
Weight	2.2 kg (4.8 lb)

Appendix B: Syringe Inside Diameter

<i>Terumo</i>		<i>Stainless Steel</i>		<i>SGE</i>	
<u>Size</u>	<u>Diameter</u>	<u>Size</u>	<u>Diameter</u>	<i>Scientific Glass</i>	
3 cc	8.95 mm	8 cc	9.525 mm	<i>Engineering</i>	
5	13.00	20 cc	19.130	<u>Size</u>	<u>Diameter</u>
10	15.80	50 cc	28.600	25 μ l	0.73 mm
20	20.15	100 cc	34.900	50	1.03
30	23.10			100	1.46
60	29.10			250	2.30
				500	3.26
<i>Sherwood Monoject</i>		<i>Becton Dickinson</i>		1.0 ml	4.61 mm
<i>Plastic</i>		<u>Size</u>	<u>Diameter</u>	2.5	7.28
<u>Size</u>	<u>Diameter</u>	1 cc	4.78 mm	5	10.30
1 cc	4.65 mm	3	8.66	10	14.57
3	8.94	5	12.06		
6	12.70	10	14.50		
12	15.90	20	19.13		
20	20.40	30	21.70		
35	23.80	50/60	26.70		
60	26.60				
140	38.40				
<i>Popper & Sons, Inc.</i>		<i>Air Tite "All Plastic"</i>			
<i>"Perfektum" Glass</i>		<u>Size</u>	<u>Diameter</u>	<u>Size</u>	<u>Diameter</u>
<u>Size</u>	<u>Diameter</u>	2.5 cc	9.60 mm	.5 μ l	0.103 mm
0.25 cc	3.45 mm	5.0	12.45	1	0.1457
0.5	3.45	10	15.90	2	0.206
1	4.50	20	20.05	5	0.3257
2	8.92	30	22.50	10	0.460
3	8.99	50	29.00	25	0.729
5	11.70			50	1.031
10	14.70			100	1.46
20	19.58			250	2.3
30	22.70			500	3.26
50	29.00				
100	35.70				
		<i>Unimetrics</i>		1.0 ml	4.61 mm
		<u>Size</u>	<u>Diameter</u>	2.5	7.28
		10 μ l	0.460 mm	5	10.3
		25	0.729	10	14.57
		50	1.031	25	23.0
		100	1.460	50	32.6
		250	2.300		
		500	3.260		
		1000	4.610		

Appendix C: Flow Rates

Harvard Apparatus Pump '11' Plus Syringe Pump

nominal syringe size	nominal diameter (mm)	$\mu\text{l/hr}$		$\mu\text{l/min}$		ml/hr		ml/min	
		min	max	min	max	min	max	min	max
Min	0.10	0.0014	22.35	0.0001	0.3725	0.0001	0.0223	0.0001	0.0003
1 μl	0.15	0.0031	50.29	0.0001	0.8383	0.0001	0.0502	0.0001	0.0008
2 μl	0.21	0.0061	98.58	0.0002	1.6430	0.0001	0.0985	0.0001	0.0016
5 μl	0.33	0.0149	243.4	0.0003	4.057	0.0001	0.2434	0.0001	0.0040
10 μl	0.46	0.0289	473.0	0.0005	7.883	0.0001	0.4730	0.0001	0.0078
25 μl	0.73	0.0728	1,191	0.0013	19.85	0.0001	1.191	0.0001	0.0198
50 μl	1.03	0.1448	2,371	0.0025	39.52	0.0002	2.371	0.0001	0.0395
100 μl	1.46	0.2909	4,765	0.0049	79.41	0.0003	4.765	0.0001	0.0794
250 μl	2.30	0.7218	9,999	0.0121	197.0	0.0008	11.82	0.0001	0.1970
1,000 μl	3.26	1.451	9,999	0.0242	395.7	0.0015	23.75	0.0001	0.3959
1 ml	4.61	2.900	9,999	0.0484	791.8	0.0029	47.50	0.0001	0.7918
2.5 ml	7.28	7.232	9,999	0.1206	1,974	0.0073	118.4	0.0002	1.974
3 ml	8.66	10.24	9,999	0.1706	2,794	0.0103	167.6	0.0002	2.794
5 ml	10.30	14.50	9,999	0.2413	3,952	0.0145	237.1	0.0003	3.952
10 ml	14.57	28.97	9,999	0.4828	7,909	0.0290	474.5	0.0005	7.909
20 ml	20.05	54.86	9,999	0.9142	9,999	0.0549	898.6	0.0010	14.97
30 ml	23.10	72.81	9,999	1.214	9,999	0.0729	1,192	0.0013	19.88
50 ml	26.70	97.27	9,999	1.622	9,999	0.0973	1,576	0.0017	26.56
Max	35.00	167.2	9,999	2.786	9,999	0.1672	2,738	0.0028	45.64

Appendix D: Serial Communication

Commands, Queries and Responses

After each transmission to the pump terminating with a CR character (ASCII 13), the pump enters remote mode and responds with the three character sequence:

CR LF ***prompt***

The prompt character indicates the status of the pump as follows:

<u>prompt</u>	<u>meaning</u>	<u>ASCII code</u>
:	When stopped	(ASCII 58 decimal)
>	When running forward	(ASCII 62 decimal)
*	When stalled	(ASCII 42 decimal)

Pump 11 does not include stall detection

Serial commands and their meanings:

Commands:

KEY	Return to keyboard control. Exit remote mode
RUN	Start infuse (forward direction)
STP	Stop motor
CLV	Clears volume accumulator to zero
CLT	Clears target volume to zero, dispense disabled
REV	Start (Reverse Direction)

Commands with numbers:

MMD	number	Set syringe diameter, units are mm. Rate is set to zero after MMD command.
ULM	number	Set flow rate and range, units are microliters per minute
MLM	number	Set flow rate and range, units are milliliters per minute
ULH	number	Set flow rate and range, units are microliters per hour
MLH	number	Set flow rate and range, units are milliliters per hour
MLT	number	Set target infusion volume, units are ml or µl depending on range

Numbers can be between 0 and 1999.

Leading zeros and trailing decimal point are optional. Any number of digits to the right of the decimal point may be transmitted. The number will be rounded.

Appendix D: Serial Communication

Queries:

- DIA** Returns diameter value units in mm
- RAT** Returns rate value set in current range units
- VOL** Returns current accumulated infused volume, units in ml or μ l depending on range
- VER** Returns model and version number of firmware
- TAR** Returns target volume, units in ml or μ l depending on range

value format: **nnnn.nnn**

The returned value is an 8 character string with leading zeros converted to SP characters (ASCII 32 decimal). The fifth character is a decimal point (ASCII 46 decimal)

Queries with string response:

- RNG** Returns range message (character string either: ML/H ML/M UL/H UL/M)

Error responses:

- CR LF ? CR LF prompt** Unrecognized command
- CR LF OOR CR LF prompt** Entered value in out of range

Appendix E: Dual RS-232

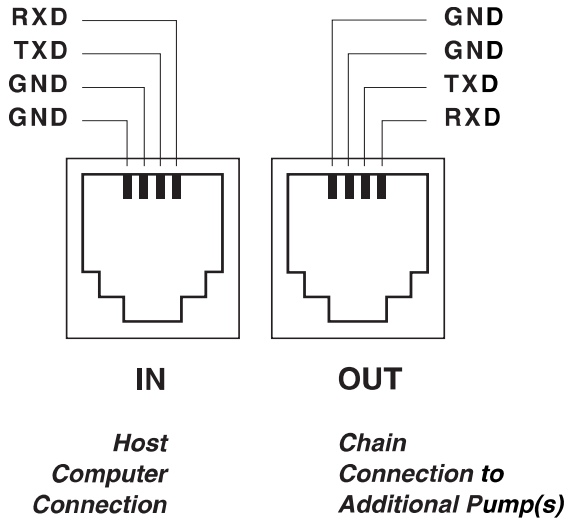

Daisy-Chain Connector & Cables

Part No.	Description
70-2022	RS232 serial cable, 6 ft long, 9 pin d-sub on one end, and RJ11 on the other end
72-2478	Daisy Chain Cable, 6 ft
55-7760	Daisy Chain Cable, 2 ft

Harvard Apparatus pumps are distributed
on a non-exclusive basis by:

INSTECH

Instech Laboratories, Inc.

Headquarters:
5209 Militia Hill Road
Plymouth Meeting, PA 19462
TL (800) 443-4227
TL (610) 941-0132
FX (610) 941-0134

European sales office:
P.O. Box 2
9950 AA Winsum
The Netherlands
TL 0031-(0)594-696123

www.instechlabs.com/Pumps/syringe/